

# Math 116 — First Midterm

October 10 , 2012

Name: \_\_\_\_\_ EXAM SOLUTIONS \_\_\_\_\_

Instructor: \_\_\_\_\_ Section: \_\_\_\_\_

1. **Do not open this exam until you are told to do so.**
2. This exam has 11 pages including this cover. There are 7 problems. Note that the problems are not of equal difficulty, so you may want to skip over and return to a problem on which you are stuck.
3. Do not separate the pages of this exam. If they do become separated, write your name on every page and point this out to your instructor when you hand in the exam.
4. Please read the instructions for each individual problem carefully. One of the skills being tested on this exam is your ability to interpret mathematical questions, so instructors will not answer questions about exam problems during the exam.
5. Show an appropriate amount of work (including appropriate explanation) for each problem, so that graders can see not only your answer but how you obtained it. Include units in your answer where that is appropriate.
6. You may use any calculator except a TI-92 (or other calculator with a full alphanumeric keypad). However, you must show work for any calculation which we have learned how to do in this course. You are also allowed two sides of a  $3'' \times 5''$  note card.
7. If you use graphs or tables to find an answer, be sure to include an explanation and sketch of the graph, and to write out the entries of the table that you use.
8. **Turn off all cell phones and pagers**, and remove all headphones.

---

Problem	Points	Score
1	12	
2	18	
3	20	
4	16	
5	12	
6	12	
7	10	
Total	100	

1. [12 points] Indicate if each of the following is true or false by circling the correct answer. No justification is required.

- a. [2 points] Let  $u(x)$  and  $v(x)$  be differentiable functions with  $u(0) = u(1) = 0$ , then

$$\int_0^1 u(x)v'(x)dx = - \int_0^1 u'(x)v(x)dx.$$

 True

 False

*Solution:* Using integration by parts

$$\int_0^1 u(x)v'(x)dx = -u(x)v(x) \Big|_0^1 - \int_0^1 u'(x)v(x)dx = - \int_0^1 u'(x)v(x)dx.$$

- b. [2 points] The function  $f(x) = \int_0^{x^2} e^{t^2} dt$  is decreasing for  $x < 0$ .

 True

 False

*Solution:*  $f'(x) = 2xe^{x^4} < 0$  for  $x < 0$ , hence  $f(x)$  is decreasing for  $x < 0$ .

- c. [2 points] For any differentiable function  $f(x)$

$$\int_0^x f'(t)dt = \frac{d}{dx} \left( \int_0^x f(t)dt \right).$$

 True

 False

*Solution:*

$$\int_0^x f'(t)dt = f(x) - f(0) \text{ by the Fundamental Theorem of Calculus}$$

$$\frac{d}{dx} \left( \int_0^x f(t)dt \right) = f(x) \text{ by the Second Fundamental Theorem of Calculus}$$

Hence it is not true for functions for which  $f(0) \neq 0$ , example  $f(x) = x + 1$ .

- d. [2 points] If the mass density function of a square plate (shown below) is  $\delta(y)$ , an even function of  $y$  only, then the center of mass of the plate lies on the  $x$ -axis.

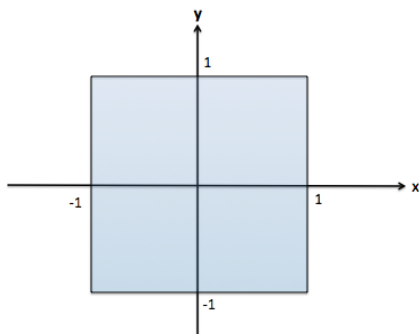

True

False

*Solution:* The  $y$ -coordinate of the center of mass is given by

$$\bar{y} = \frac{\int_{-1}^1 2\delta(y)ydy}{\int_{-1}^1 2\delta(y)dy} = 0.$$

Since the integrand  $2\delta(y)y$  is an odd function of  $y$ , then  $\int_{-1}^1 2\delta(y)ydy = 0$ .

- e. [2 points] If we use the trapezoidal rule to approximate the integral  $I = \int_0^1 (1+2t)dt$  then Trap( $n$ ) is exactly equal to  $I$  for every  $n$ .

True

False

*Solution:* The area represented by  $\int_0^1 (1+2t)dt$  is a trapezoid, hence the trapezoid rule gives you the exact value of this area.

- f. [2 points] If  $f(x)$  is concave up, then the average value of  $f(x)$  on the interval  $[0, 2]$  is larger than  $f(1)$ .

True

False

*Solution:* If  $A$  is the average value of  $f(x)$  on the interval  $[0, 2]$ , then  $2A = \int_0^2 f(x)dx$ . We know that if  $f(x)$  is concave up, then  $f(1) < \frac{1}{2} \int_0^2 f(x)dx = A$ . Hence  $f(1) < A$ .

2. [18 points] The graph of the function  $f(x)$ , shown below, consists of line segments and a semicircle. Compute each of the following quantities.

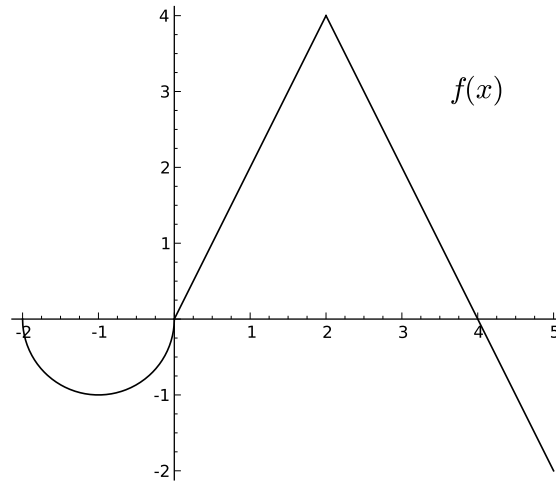

- a. [7 points]

$$1. \int_0^2 f(x) dx = 4.$$

$$2. \int_{-2}^2 |f(x)| dx = \frac{\pi}{2} + 4 \approx 5.57.$$

$$3. \int_0^5 f(x) dx = 8 - 1 = 7.$$

$$4. \int_{-2}^2 2f(x) dx + \int_5^2 3f(x) dx = 2(4 - \frac{\pi}{2}) - 3(4 - 1) = -1 - \pi \approx -4.14.$$

$$5. \text{ The average } A \text{ of } f(x) \text{ on the interval } [-2, 5]. \quad A = \frac{1}{7} \int_{-2}^5 f(x) dx = \frac{7 - \frac{\pi}{2}}{7} \approx .775.$$

$$6. \int_0^1 f(5x) dx = \frac{1}{5} \int_0^5 f(u) du = \frac{7}{5}.$$

b. [4 points]

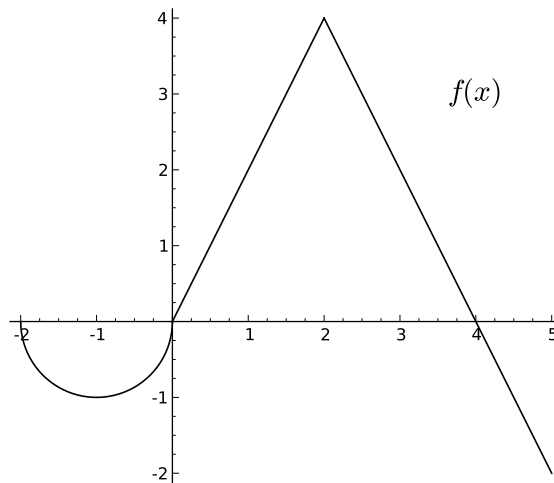

If  $f(x)$  is the derivative of a function  $g(x)$  with  $g(2) = 1$ , fill in the table of values of  $g(x)$ , provided below, at the specified points (the graph has been reproduced for your convenience):

$x$	-2	0	2	4	5
$g(x)$	$\frac{\pi}{2} - 3 \approx -1.429$	-3	1	5	4

c. [5 points] Graph  $g(x)$ . Make sure your graph indicates the intervals on which  $g(x)$  is increasing, decreasing, concave up, and concave down.

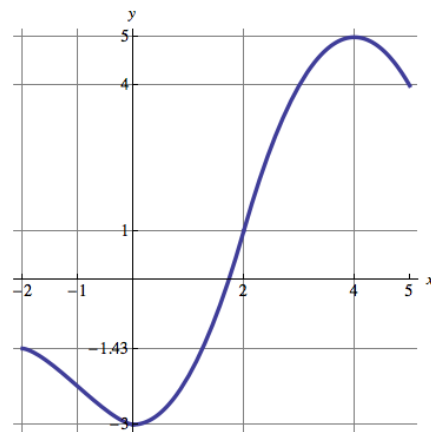

d. [2 points] Let  $h(x) = \int_0^x f(t) dt$ . Find a constant  $C$  such that  $g(x) = h(x) + C$ . Show all your work.

$$g(x) = 1 + \int_2^x f(t) dt = 1 + \int_0^x f(t) dt - \int_0^2 f(t) dt = 1 + h(x) - 4$$

$$g(x) = h(x) - 3.$$

$$C = -3.$$

3. [20 points] A tank initially contains  $20 \text{ m}^3$  of water. Water is poured into the tank at a rate of  $I(t) \text{ m}^3$  per hour. At the same time, water is pumped out of the tank at a rate of  $O(t) \text{ m}^3$  per hour. The graphs of  $I(t)$  and  $O(t)$  are shown below.

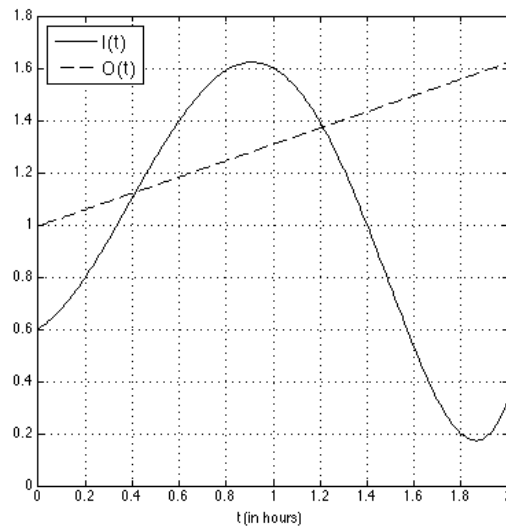

- a. [5 points] Find an expression for  $V(t)$ , the volume of the water in the tank at time  $t$ . Include units.

$$\text{Solution: } V(t) = 20 + \int_0^t I(x) - O(x) dx \text{ m}^3.$$

- b. [1 point] At what time is the volume of water in the tank at a maximum?

$$\text{Solution: } \text{At } t = 1.2 \text{ hours.}$$

- c. [2 points] At what time is the volume of water in the tank at a minimum?

$$\text{Solution: } \text{At } t = 2 \text{ hours.}$$

- d. [2 points] For which values of  $t$  is  $V(t)$  increasing?

$$\text{Solution: } V'(t) = I(t) - O(t), \text{ hence } V(t) \text{ is increasing for } 0.4 < t < 1.2 \text{ (when } I(t) > O(t)\text{).}$$

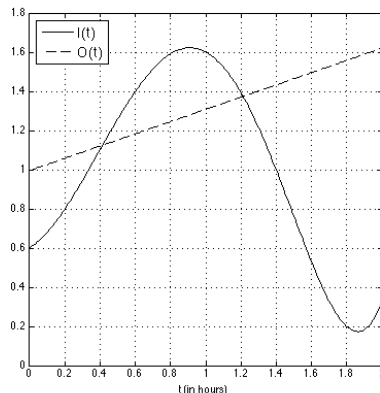

- e. [3 points] For which values of  $t$  is  $V(t)$  concave up? For which values is it concave down?

*Solution:*  $V''(t) = I'(t) - O'(t)$ , Hence the inflection points are  $t = 0.8$  and  $t = 1.9$  (when  $I'(t) = O'(t)$ ).

Concave up:  $(0, 0.8), (1.9, 2)$   $I'(t) > O'(t)$

Concave down:  $(0.8, 1.9)$   $I'(t) < O'(t)$

- f. [4 points] Find an estimate for  $\int_0^2 I(t) dt$  using Mid(5). Write all the terms in the sum.

*Solution:*

$$\begin{aligned} MID(5) &= 0.4 [I(0.2) + I(0.6) + I(1) + I(1.4) + I(1.8)] \\ &= 0.4 [0.8 + 1.4 + 1.6 + 1 + 0.2] = 2. \end{aligned}$$

- g. [3 points] Suppose instead of the function  $O(t)$  shown in the graph above, the water is pumped out of the tank at a constant rate of  $r \text{ m}^3$  per hour. What must the value of  $r$  be so that  $V(2) = 20$ ? Your answer may involve a definite integral of  $I(t)$ .

*Solution:*

$$V(2) = 20 + \int_0^2 I(x) - r dx = 20.$$

$$\text{Hence } \int_0^2 I(x) - r dx = 0.$$

$$\text{Then } \int_0^2 I(x) dx = \int_0^2 r dx = 2r$$

$$r = \frac{1}{2} \int_0^2 I(x) dx \quad \text{the average value of } I(x) \text{ on } [0, 2].$$

4. [16 points] Consider the region  $R$  bounded by the graphs of  $y = \ln(x)$ ,  $y = 0$  and  $x = 2$ . In the following questions, show all your work to receive full credit.

a. [4 points] Find the perimeter of the region  $R$ . You may use your calculator to evaluate any integrals.

$$\text{Solution: } L = 1 + \ln 2 + \int_1^2 \sqrt{1 + \left(\frac{1}{x}\right)^2} dx \approx 2.915.$$

b. [5 points] Let  $S$  be the solid obtained by rotating the region  $R$  about the  $y$  axis. Write an expression for the volume of a slice of the solid  $S$  located at a height  $y$  with thickness  $\Delta y$ .

$$\text{Solution: } V_{\text{slice}} \approx \pi[4 - e^{2y}]\Delta y.$$

c. [2 points] Suppose  $S$  has mass density  $\delta(y) = e^{-y}$ . Write an expression for the mass of the solid  $S$  using a definite integral. You do not need to evaluate this integral.

$$\text{Solution: } \text{Mass} = \int_0^{\ln 2} e^{-y} \pi[4 - e^{2y}] dy.$$

d. [2 points] What is the value of  $\bar{x}$ , the  $x$  coordinate of the center of mass of  $S$ ? Justify.

*Solution:*  $S$  is a solid of revolution where the  $y$  axis is its axis of symmetry and the mass density  $\delta(y)$  is independent of  $x$ , hence the center of mass should be on the  $y$  axis. Hence  $\bar{x} = 0$ .

e. [3 points] Write an expression for  $\bar{y}$ , the  $y$  coordinate of the center of mass of  $S$ , using definite integrals. You do not need to evaluate this expression.

$$\text{Solution: } \bar{y} = \frac{\int_0^{\ln 2} y e^{-y} \pi[4 - e^{2y}] dy}{\int_0^{\ln 2} e^{-y} \pi[4 - e^{2y}] dy}.$$



5. [12 points] Oil leaks from a tank on the shore of a lake to form a semicircular slick on the surface of the water (as shown in the figure below). A team of environmentalists is trying to estimate the amount of oil spilled. They took measurements of the density  $P$  of oil (in kg per  $\text{m}^2$ ) in the slick and found that it was a function of the distance  $r$  (in m) from the source of the oil.

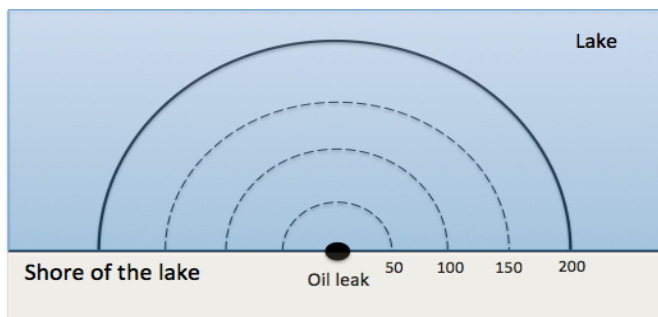

The values of  $P(r)$  measured by the environmentalists are shown in the table below.

$r$	0	50	100	150	200
$P(r)$	100	40	12	10	8

- a. [6 points] Write an expression involving integrals for the exact value of the mass of the oil in the lake inside a semicircle centered at the oil leak with a radius of 200 meters (see the figure above). Include units.

*Solution:*  $\text{Mass}_{oil} = \int_0^{200} \pi r P(r) dr \text{ kg.}$

- b. [4 points] Find approximations to your answer in part (a) using Left(4) and Right(4). Show your work by writing all the terms of the sums.

*Solution:*

$r$	0	50	100	150	200
$P(r)$	100	40	12	10	8
$\pi r P(r)$	0	6,283.2	3,769.9	4,712.4	5,026.5

$$\text{Left}(4) = 50(6,283.2 + 3,769.9 + 4,712.4) = 738,274.27 \text{ kg}$$

$$\text{Right}(4) = 50(6,283.2 + 3,769.9 + 4,712.4 + 5,026.5) = 989,601.68 \text{ kg}$$

- c. [2 points] The environmentalists notice that the density  $P(r)$  of oil is a decreasing function. Does this observation guarantee that one of the approximations in part (b) yields an overestimate? If so, which one? Justify.

*Solution:* To get an overestimate, the function  $Q(r) = \pi r P(r)$  needs to be either increasing or decreasing for  $0 \leq r \leq 200$ . The fact that  $P(r)$  is decreasing it is not enough. In this case,  $Q(r)$  is neither increasing or decreasing (look at its values at  $r = 0, 50, 100$ ).

6. [12 points] A tank whose base is at ground level has lateral walls in the form of a trapezoid 3 meters wide at the bottom, 4 meters wide at the top, and 3 meters high, and has a length of 7 meters, as shown in the figures below. The tank contains water up to a level of 1 meter. The density of water is  $1000 \text{ kg per m}^3$ .

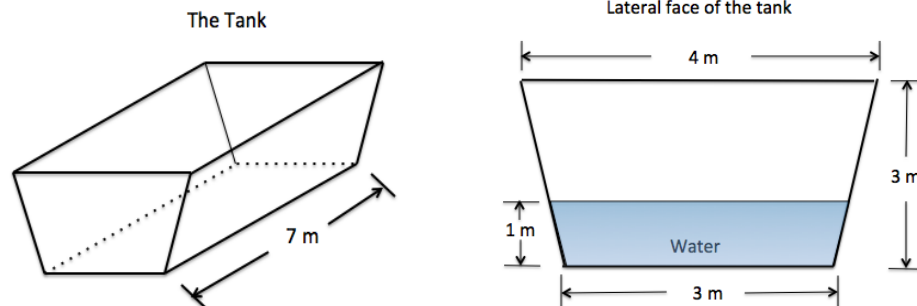

- a. [8 points] Write an expression that approximates the work done in lifting a horizontal slice of water with thickness  $\Delta h$  that is at a height of  $h$  meters above the ground to the top of the tank. Use  $g = 9.8 \text{ m/s}^2$  for the acceleration due to gravity.

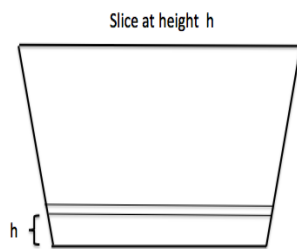

$$\text{Solution: } \text{Work}_{\text{slice}} \approx 1000\left(\frac{1}{3}h + 3\right)(7)g(3 - h)\Delta h \approx 68600\left(\frac{1}{3}h + 3\right)(3 - h)\Delta h$$

- b. [4 points] Write an expression for the work required to pump all the water in the tank to the top of the tank. You do not need to evaluate the expression. Include units.

$$\text{Solution: } \text{Work}_{\text{water}} = \int_0^1 68600 \left(\frac{1}{3}h + 3\right) (3 - h) dh \text{ Joules.}$$

7. [10 points] Consider the solid  $S$  whose base is the region bounded by the circle  $x^2 + y^2 = 4$  and the  $y$ -axis with  $0 \leq x \leq 2$  in the  $xy$ -plane, and whose cross-sections perpendicular to the  $x$ -axis are half ellipses. The major and minor axes of the ellipses satisfy  $a = \frac{1}{4}b$  (see the picture below). The  $x$  and  $y$  are measured in centimeters.

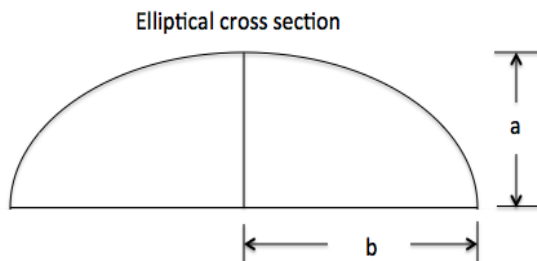

The area of an ellipse is  $A = \pi ab$ .

- a. [6 points] Write a definite integral that computes the volume of the solid  $S$ . You do not need to evaluate the integral. Include units.

*Solution:*

$$V_{\text{slice}} \approx A_{\text{slice}} \Delta x = \frac{1}{2} \pi ab \Delta x = \frac{1}{2} \pi \left( \frac{1}{4} \sqrt{4-x^2} \right) \left( \sqrt{4-x^2} \right) \Delta x$$

$$V_{\text{slice}} \approx \frac{1}{8} \pi (4-x^2) \Delta x.$$

$$V_{\text{solid}} = \int_0^2 \frac{1}{8} \pi (4-x^2) dx \text{ cm}^3$$

- b. [4 points] The mass density of  $S$  is  $\delta(x) = 4 + x^2$  mg per  $\text{cm}^3$ . Find the mass of  $S$ . You may use your calculator to evaluate any integrals. Include units.

*Solution:*

$$\text{Mass}_{\text{solid}} = \int_0^2 \frac{1}{8} \pi (4-x^2)(4+x^2) dx \approx 10.053 \text{ mg}$$