

Math 116 — Midterm Exam

October 10, 2016

UMID: _____ Initials: _____

Instructor: _____ Section: _____

1. **Do not open this exam until you are told to do so.**
 2. **Do not write your name anywhere on this exam.**
 3. This exam has 10 pages including this cover. There are 9 problems. Note that the problems are not of equal difficulty, so you may want to skip over and return to a problem on which you are stuck.
 4. Do not separate the pages of this exam. If they do become separated, write your UMID on every page and point this out to your instructor when you hand in the exam.
 5. Please read the instructions for each individual problem carefully. One of the skills being tested on this exam is your ability to interpret mathematical questions, so instructors will not answer questions about exam problems during the exam.
 6. Show an appropriate amount of work (including appropriate explanation) for each problem so that graders can see not only your answer, but also how you obtained it. Include units in your answer where that is appropriate.
 7. You may use a TI-84, TI-89, TI-Nspire or other approved calculator. However, you must show work for any calculation which we have learned how to do in this course. You are also allowed two sides of a $3'' \times 5''$ note card.
 8. If you use graphs or tables to find an answer, be sure to include an explanation and sketch of the graph, and to write out the entries of the table that you use.
 9. **Turn off all cell phones, pagers, and smartwatches**, and remove all headphones.
-

Problem	Points	Score
1	13	
2	16	
3	11	
4	15	
5	7	
6	12	
7	6	
8	6	
9	14	
Total	100	

1. [13 points] Suppose that f is a twice-differentiable, function that satisfies

$$f(0) = 1 \qquad f(2) = 2 \qquad f(4) = 4 \qquad f'(2) = 3$$

$$\int_0^2 f(x) dx = 5 \qquad \int_2^4 f(x) dx = 7.$$

Evaluate the following integrals.

a. [4 points] $\int_0^2 x f'(x) dx$

b. [4 points] $\int_{\sqrt{2}}^2 x f'(x^2) dx$

c. [5 points] $\int_0^2 x^3 f'(x^2) dx$

2. [16 points] The local sparrow population has been fluctuating unnaturally, and Raymond Green has five months of data to prove it. Let $S(t)$ denote the local sparrow population **in thousands**, t months after Green started collecting data. A graph of $S'(t)$, the rate of population growth, is below. Assume there are 2000 sparrows at $t = 1$.

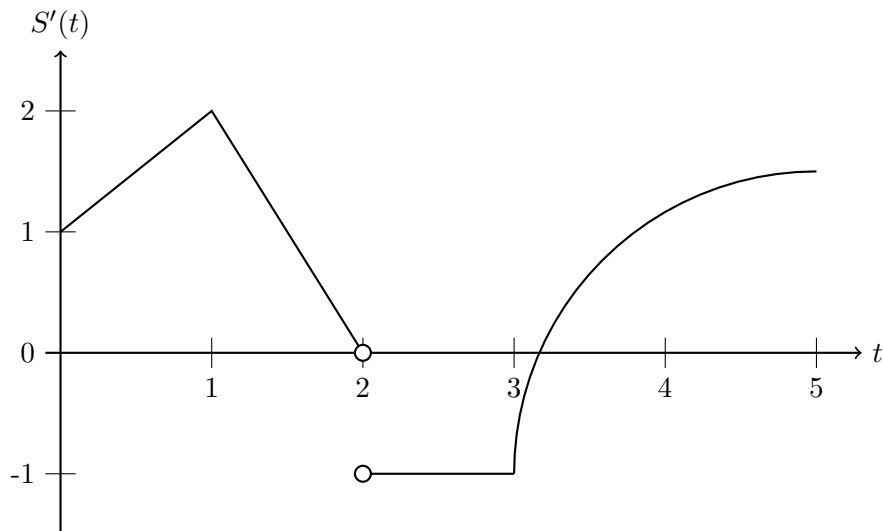

- a. [1 point] At which t -value(s) is the sparrow population increasing the fastest?

- b. [3 points] What is the local sparrow population at $t = 0$, $t = 2$ and $t = 3$?

- c. [2 points] At which t -values is the population at its highest and lowest?

2 (continued). Recall that $S(t)$ is the local sparrow population in thousands, t months after Green began collecting data.

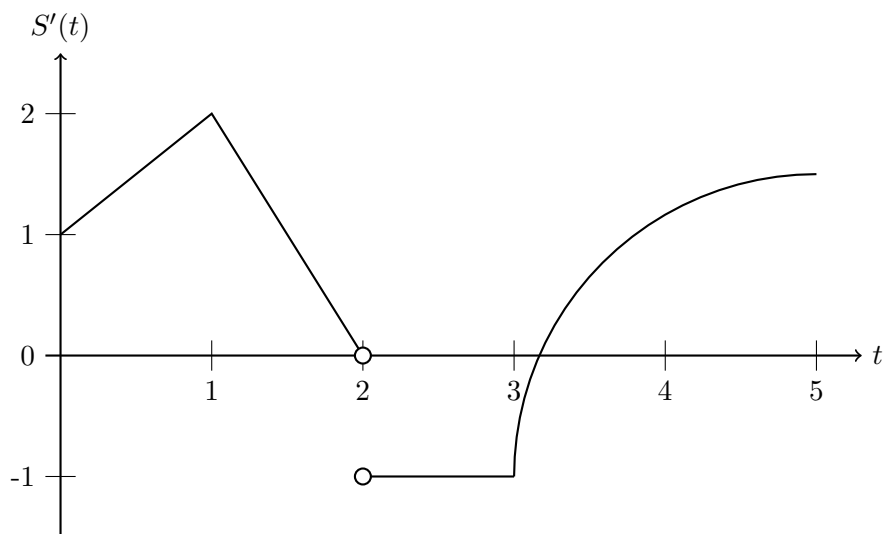

d. [10 points] Sketch a graph of $S(t)$ on the axes below, recalling that there are 2000 sparrows at $t = 1$. Label your vertical axis. Make sure that concavity and local extrema are clear.

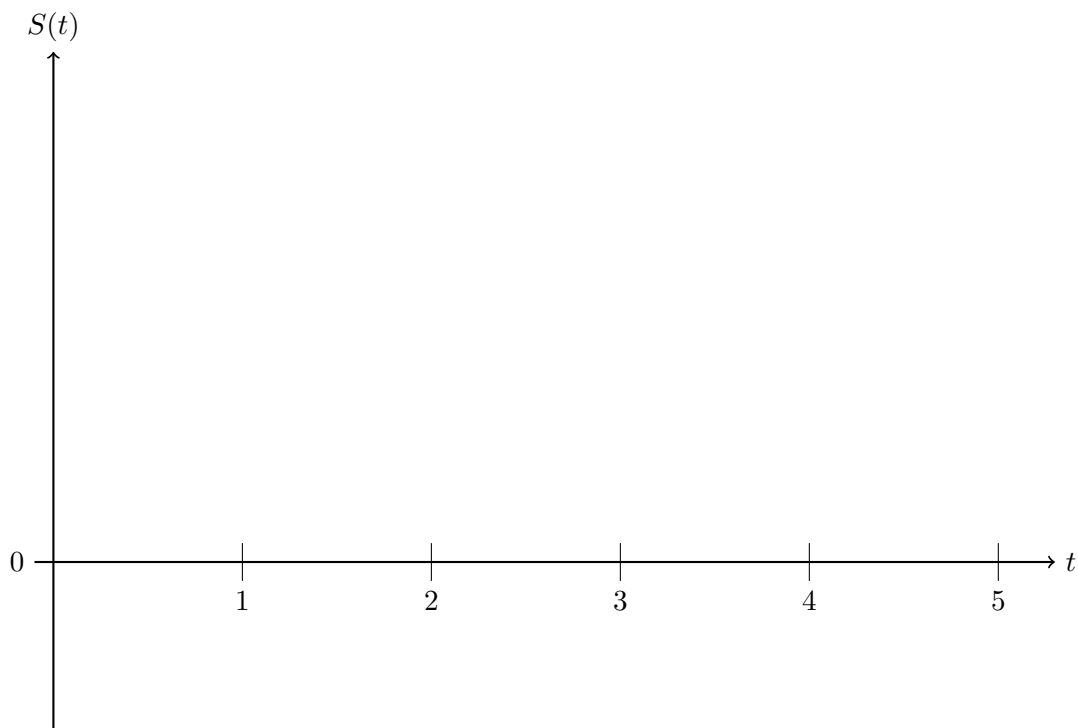

3. [11 points] During a trip to the local aquarium, Steph becomes curious and decides to taste the fish food. The fish food tank is completely filled with food, and it is in the shape of a pyramid with a vertical hole through its center, illustrated below (the dashed lines are not part of the tank). The tank itself is 3 m tall, and the pyramid base is a square of side length 10 m. The top and bottom of the hole are squares of side length 4 m. The food is contained in the shaded region only, **not** in the hole.

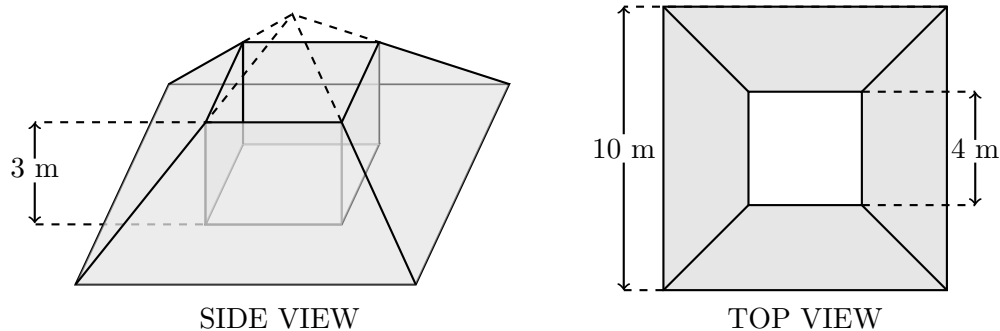

- a. [5 points] Write an expression that gives the approximate volume of a slice of fish food of thickness Δh meters, h meters from the bottom of the tank.
- b. [3 points] Suppose that the mass density of fish food is a constant δ kg/m³. Write, but do **not** evaluate, an expression involving integrals that gives the mass of fish food in the tank.
- c. [3 points] Write an expression involving integrals that gives \bar{h} , the h -coordinate of the center of mass of the fish food, where h is defined as above. Do **not** evaluate your expression.

4. [15 points] For this problem, m is a differentiable function with $m'(x) > 0$ for all x . The following table gives some values of m .

x	0	1	2	3	4	5	6	7	8
$m(x)$	0	2	3	4	6	9	10	11	12

- a. [3 points] What is the average value of $m'(x)$ on $[1, 7]$?
- b. [3 points] Use a left Riemann sum with 3 subdivisions to estimate $\int_2^8 m(x) dx$. Write out each term of your sum. Is this an overestimate or underestimate?
- c. [3 points] Use a midpoint sum with 3 subdivisions to estimate $\int_0^{12} m^{-1}(y) dy$. Write out each term of your sum.
- d. [6 points] Consider the region bounded by the y -axis, the line $y = 12$ and the curve $y = m(x)$. Write an integral that gives the volume of the solid obtained by rotating this region about the y -axis. Use a right Riemann sum with 2 subdivisions to estimate your integral. Write out each term of your sum.

5. [7 points] On his day off, Dr. Durant is experimenting with graphene, a remarkable material that comes in thin sheets. The graphene sample he is currently working with is shaped like the region in the first quadrant shaded below, where $c > 0$ is some positive constant and the units of the axes are mm. Suppose that the mass density of the sample is given by $\delta(x)$ g/mm².

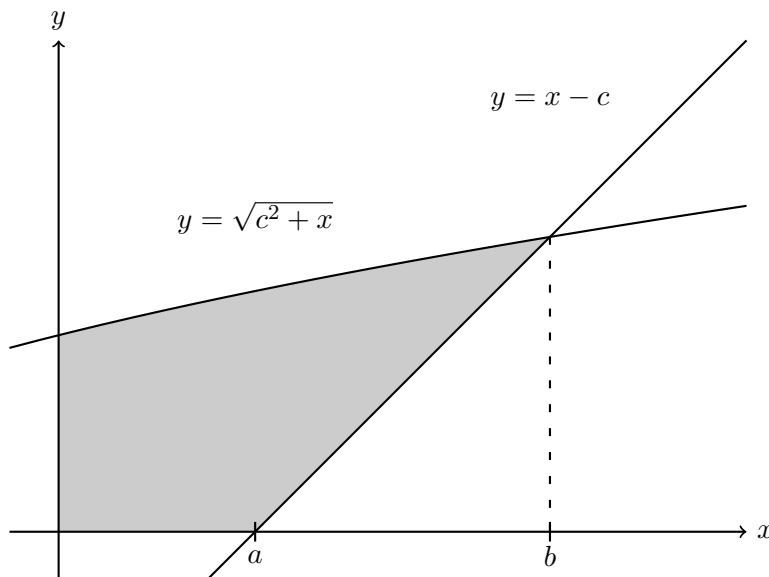

- a. [3 points] Find a and b . Your answers may include c .
- b. [4 points] Write, but do **not** evaluate, an expression involving integrals that gives the mass of the sample.

6. [12 points]

- a. [3 points] Let f be a positive, continuous function. Which of the following are antiderivatives of f whose graphs go through the point $(1, 0)$? Circle **all** that apply.

$$\int_0^1 f(t) dt \quad \int_0^x f(t) dt + \int_1^0 f(t) dt \quad \int_0^x f(t) dt$$

$$\int_2^{2x} f(t/2) dt \quad \frac{1}{2} \int_2^{2x} f(t/2) dt$$

- b. [3 points] Let R be the region between the x -axis and the graph of some positive, continuous function from $x = a$ to $x = b$. If V is the volume of the solid whose base is R and whose cross-sections parallel to the y -axis are semicircles, what is the volume of the solid whose base is R and whose cross-sections parallel to the y -axis are equilateral triangles?

$$\frac{\sqrt{3}}{4}V \quad \frac{2\sqrt{3}}{\pi}V \quad \frac{4\sqrt{3}}{\pi}V \quad 2\pi V \quad \frac{2\pi}{\sqrt{3}}V$$

- c. [3 points] Which of the following expressions gives the arclength of the graph of $y = \sin(x^2)$ from $x = 0$ to $x = \sqrt{\pi}$?

$$\int_0^{\sqrt{\pi}} \sqrt{1 + 2x^2 \sin^2(x^2)} dx \quad \int_0^{\sqrt{\pi}} \sqrt{1 + \sin^2(x^2)} dx \quad \int_0^{\pi} \sqrt{1 + 4x^2 \cos^2(x^2)} dx$$

$$\int_0^{\sqrt{\pi}} \sqrt{1 + \cos^2(x^2)} dx \quad \int_0^{\sqrt{\pi}} \sqrt{1 + 4x^2 \cos^2(x^2)} dx$$

- d. [3 points] If the average value of a continuous function is A on $[0, 3]$ and B on $[3, 5]$, what is its average value on $[0, 5]$?

$$2A + 3B \quad \frac{2A + 3B}{5} \quad \frac{A + B}{2} \quad \frac{3A + 2B}{5} \quad \frac{A + B}{5}$$

7. [6 points] Suppose that g is a continuous function, and define another function G by

$$G(x) = \int_0^x g(t) dt.$$

Given that $\int_0^7 g(x) dx = 5$, compute

$$\int_0^7 g(x)(G(x))^2 dx.$$

Show each step of your computation.

8. [6 points] Suppose that f is a continuous, **odd** function, and define another function F by

$$F(x) = \int_{-12}^x f(3t - c) dt,$$

where c is some constant. You do not need to show your work for this problem.

- a. [3 points] Find a value of c for which the graph of F goes through the origin.

- b. [3 points] Find a value of c for which the graph of F' goes through the origin.

9. [14 points] In a secret room at ShamCorp headquarters, there is a strangely-shaped transparent container filled with fluorescent purple liquid called “the key”. The key is in the shape of a solid with semicircular base of radius one meter, and with semicircular cross sections perpendicular to the straight side of the base. The key is suspended in the room with its semicircular cross sections parallel to the floor. The key has a volume of $\frac{\pi}{6} \text{ m}^3$, and the purple liquid has a density of 1500 kg/m^3 . The container that holds the purple liquid is infinitely thin and has no mass. For your reference, the gravitational constant is $g = 9.8 \text{ m/s}^2$.
- a. [7 points] One day, Dr. Durant orders Steph to move the key 2 meters higher. As soon as Steph begins to move the key straight up at a constant rate of 6 meters per minute, purple liquid starts leaking out of the key at a constant rate of $300\pi \text{ kg}$ per minute. Write an expression involving integrals that gives the work done by Steph moving the key 2 meters higher as it’s leaking. Do not evaluate your integral.
- b. [7 points] Periodically, Steph has to do her least favorite job — emptying the key by pumping all of the purple liquid to a height of 3 meters above the top of the key. Write an expression involving integrals that gives the work done by Steph when she does this job, assuming the key is **full** when she starts. Do not evaluate your integral.