

# Math 116 — First Midterm — October 3, 2023

**Write your 8-digit UMID number very clearly in the box to the right.**

Your Initials Only: \_\_\_\_\_ Instructor Name: \_\_\_\_\_ Section #: \_\_\_\_\_

1. Please neatly write your 8-digit UMID number, your initials, your instructor's first and/or last name, and your section number in the spaces provided.
2. This exam has 11 pages including this cover.
3. There are 9 problems. Note that the problems are not of equal difficulty, so you may want to skip over and return to a problem on which you are stuck.
4. Please read the instructions for each individual problem carefully. One of the skills being tested on this exam is your ability to interpret mathematical questions, so instructors will not answer questions about exam problems during the exam.
5. Show an appropriate amount of work (including appropriate explanation) for each problem, so that graders can see not only your answer but how you obtained it.
6. If you need more space to answer a question, please use the back of an exam page. Clearly indicate on your exam if you are using the back of a page, and also clearly label the problem number and part you are doing on the back of the page.
7. You are allowed notes written on two sides of a 3" × 5" note card. You are NOT allowed other resources, including, but not limited to, notes, calculators or other electronic devices.
8. For any graph or table that you use to find an answer, be sure to sketch the graph or write out the entries of the table. In either case, include an explanation of how you used the graph or table to find the answer.
9. Include units in your answer where that is appropriate.
10. Problems may ask for answers in *exact form*. Recall that  $x = \sqrt{2}$  is a solution in exact form to the equation  $x^2 = 2$ , but  $x = 1.41421356237$  is not.
11. You must use the methods learned in this course to solve all problems.

Problem	Points	Score
1	15	
2	14	
3	9	
4	9	
5	9	
6	15	

Problem	Points	Score
7	7	
8	15	
9	7	
Total	100	

1. [15 points] Let  $f(x)$  be a differentiable function whose derivative  $f'(x)$  is also differentiable and is always positive. Some values of  $f(x)$  and  $f'(x)$  are given in the table below:

$x$	1	2	3	4	5	6
$f(x)$	2	7	8	12	15	17
$f'(x)$	3	2	6	11	4	5

Additionally, you are given that  $\int_2^4 \frac{f(x)}{x} dx = 9$ .

Compute the exact value of the following integrals. If there is not enough information provided to determine the value of the integral, write “NEI” and clearly indicate why. Show all of your work.

a. [5 points]  $\int_1^2 (f'(t) + 4) e^{f(t)+4t} dt$

Answer: \_\_\_\_\_

b. [5 points]  $\int_2^4 f'(x) \ln x dx$

Answer: \_\_\_\_\_

c. [5 points]  $\int_{\ln 2}^{\ln 4} f(e^x) dx$

Answer: \_\_\_\_\_

2. [14 points] An **even** function  $h(x)$ , which is defined for all real numbers, is graphed on the interval  $[0, 6]$  below. Note that  $h(x)$  is linear on the intervals  $(0, 2)$  and  $(2, 4)$ , and that the shaded region has area 4.

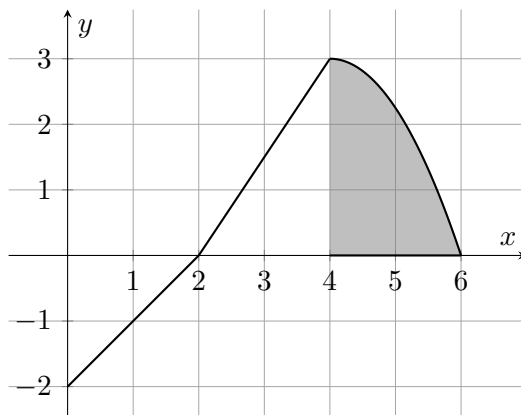

- a. [4 points] The function  $h(x)$  has a continuous antiderivative,  $H(x)$ , which satisfies  $H(2) = -3$ . Complete the following table of values for  $H(x)$ .

$x$	-2	0	2	4	6
$H(x)$			-3		

- b. [10 points] Sketch a graph of  $H(x)$  on the interval  $[-2, 6]$  using the axes provided. Make sure to clearly label the values at the points in the table above and also make it clear where  $H(x)$  is increasing or decreasing, and where  $H(x)$  is concave up, concave down, or linear.

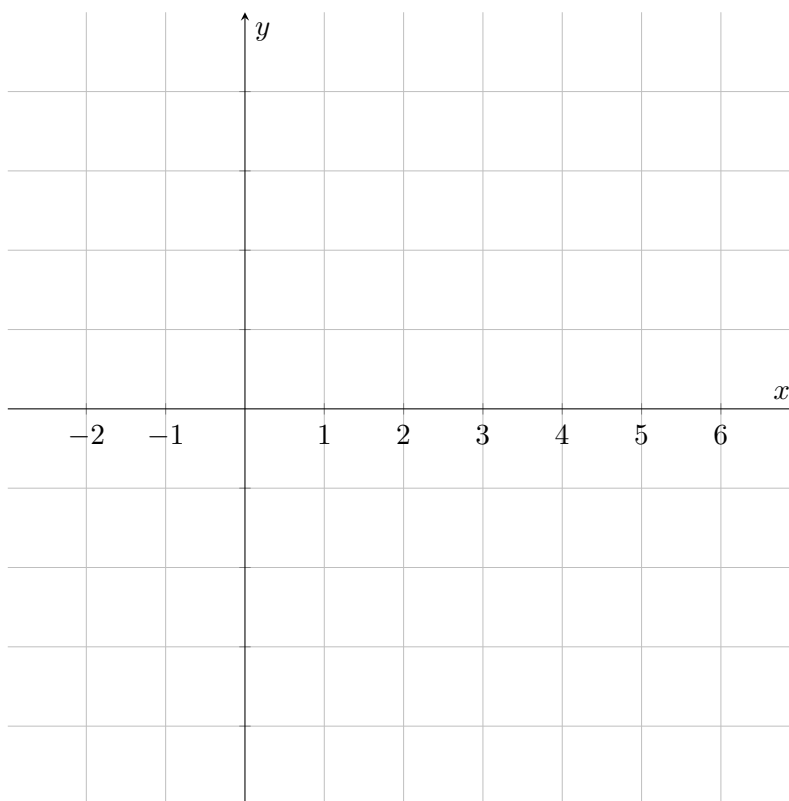

3. [9 points] Anna and Burt have come to an agreement after Labor Day's food debacle. They've decided to cook lasagna for their family's next get-together. They practice cooking the lasagna over the course of 4 hours. Let  $L(t)$  be the tastiness of the lasagna, measured in tasty units,  $t$  hours after they begin cooking.  $L(t)$  is given by

$$L(t) = \int_1^{t^2-3t+3} \frac{7}{1+x^4} dx + 3, \text{ for } 0 \leq t \leq 4.$$

- a. [2 points] There are exactly two times within the interval  $[0, 4]$  where the lasagna is 3 tasty units. What are those times? Show your work.

**Answer:** \_\_\_\_\_

- b. [4 points] During what interval(s) in  $[0, 4]$  is the lasagna's tastiness decreasing? Justify your answer(s) using calculus.

**Answer:** \_\_\_\_\_

- c. [3 points] Find a function  $f(x)$  and constants  $a$  and  $C$  so that we may rewrite  $L(t)$  in the form

$$L(t) = \int_a^t f(x) dx + C.$$

There may be more than one correct answer.

$$f(x) = \underline{\hspace{2cm}} \qquad a = \underline{\hspace{2cm}} \qquad C = \underline{\hspace{2cm}}$$

4. [9 points] As Megan's assortment of mushrooms continues to grow, she starts tracking the growth of various mushrooms. She finds that one mushroom has an erratic growth rate. Its growth rate  $t$  days after it blooms is given by the function

$$m(t) = \frac{10 \cos(t)}{(\sin^2(t) + 1)(\sin(t) + 2)} + 6 \quad \text{for } 0 \leq t \leq 5,$$

measured in centimeters per day.

The height of Megan's mushroom 5 days after it blooms is given by the integral

$$\int_0^5 m(t) dt.$$

Evaluate this integral, showing all your work. Give an exact answer and include units. You may use the fact that

$$\frac{1}{(u^2 + 1)(u + 2)} = \frac{2 - u}{5(u^2 + 1)} + \frac{1}{5(u + 2)}.$$

**Answer:** \_\_\_\_\_

5. [9 points] Jinho is playing a game involving a deck of cards, when he notices that the backs of the cards are painted in an unusual way. Jinho finds that the total mass of paint on the back of a card, in grams, can be expressed as

$$\int_3^6 (10 - g(12 - 2x)) \, dx$$

where the function  $g(x)$  is decreasing and concave up. Some of the values of  $g(x)$  are given in the following table:

$x$	0	1	2	3	4	5	6
$g(x)$	6	4	2.5	1.5	1.0	0.75	0.7

- a. [3 points] Using RIGHT(2), find an approximation for the total mass of paint, measured in grams, on the back of the card. Write out all the terms in your sum. You do not need to simplify.
- b. [3 points] Using MID(3), find an approximation for the total mass of paint, measured in grams, on the back of the card. Write out all the terms in your sum. You do not need to simplify.
- c. [3 points] Is the MID(3) estimate to the total mass of paint you found in part (b) an underestimate, an overestimate, or is there not enough information? Circle your choice and briefly explain your answer.

*Circle one:* UNDERESTIMATE    OVERESTIMATE    NOT ENOUGH INFORMATION

*Explanation:*

6. [15 points] The curves  $x = y^2 - 4y + 5$  and  $x = 5 + 2y - y^2$  intersect at the points  $(2, 3)$  and  $(5, 0)$ , as seen in the diagram below. Consider the region,  $R$ , bounded by the two curves.

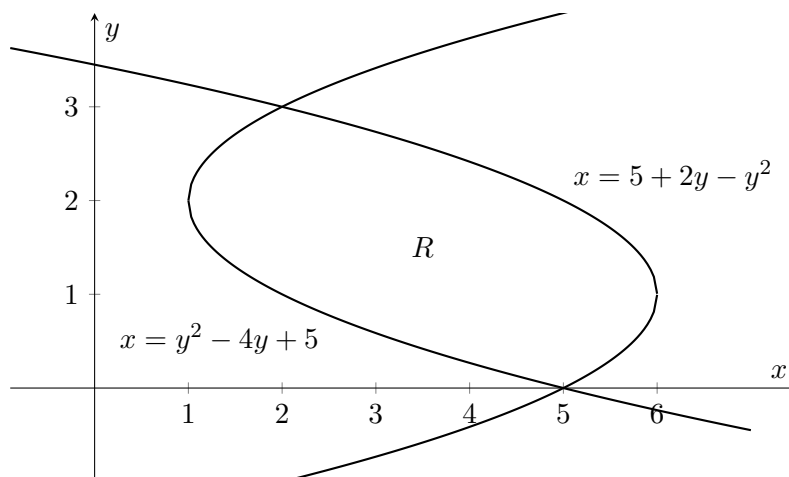

- a. [5 points] Find an expression involving one or more integrals for the volume of the solid formed by rotating the region  $R$  around the line  $x = 0$  (i.e. the  $y$ -axis). Do not evaluate your integral(s).

**Answer:** \_\_\_\_\_

- b. [5 points] Find an expression involving one or more integrals for the volume of the solid formed by rotating the region  $R$  around the line  $y = 4$ . Do not evaluate your integral(s).

**Answer:** \_\_\_\_\_

- c. [5 points] Find an expression involving one or more integrals for the volume of the solid which has the region  $R$  as its base, and which has square cross-sections perpendicular to the  $y$ -axis. Do not evaluate your integral(s).

**Answer:** \_\_\_\_\_

7. [7 points] Not content with rolling a whole boulder up a hill for all of eternity, Sisyphus instead opts to break up his punishment boulder into smaller pieces of rock and lift them up the hill inside a bucket.
- Suppose Sisyphus builds a platform at the top of the hill that is 15 feet above the ground. He lifts the bucket vertically from ground level to the platform. Unfortunately, the bucket has a hole where rocks can fall out.
- a. [3 points] Let  $W(y)$  be the weight of the bucket with rocks, in pounds, when it is  $y$  feet **above the ground**. Write an expression involving one or more integrals for the total work done to lift the bucket up to the platform. Your answer should involve  $W(y)$ . Do not evaluate your integral(s). Include units.

**Answer:** \_\_\_\_\_ **Units:** \_\_\_\_\_

- b. [4 points] Sisyphus lifts the bucket up at a constant rate of 2 feet per second. The weight of the bucket with rocks decreases at a rate of

$$r(t) = \frac{10}{1 + e^{-t}}$$

pounds per second, where  $t$  is measured in seconds since Sisyphus started lifting the bucket. Assume the bucket and the rocks together weigh 100 pounds initially. Find a formula for  $W(y)$  involving one or more integrals. Do not evaluate your integral(s).

**Answer:** \_\_\_\_\_



8. [15 points] A town's local cheese dispensary has a cheese tank that is located 3 meters below ground level. The cheese tank is in the shape of a **hemisphere with radius 6 meters**. The diagram below shows a cross-section of the tank below the ground.

Assume that the density of the cheese in the tank is given by the function  $\delta(h)$  (measured in kilograms per cubic meter), where  $h$  is measured in meters from the **top of the tank**. You may assume that the acceleration due to gravity is  $g = 9.8\text{m/s}^2$ .

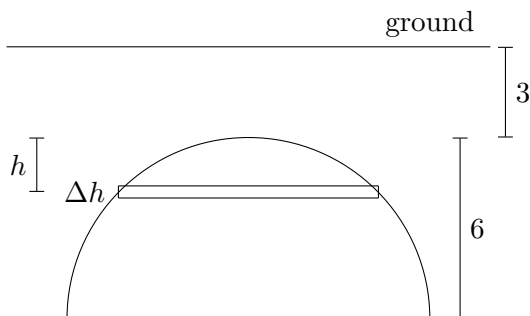

- a. [5 points] Consider a horizontal slice of cheese,  $h$  meters from the top of the tank with a small thickness of  $\Delta h$  meters, as depicted in the diagram above. Write an expression which approximates the mass of this slice as a function of  $h$ . Your answer may include  $\delta(h)$ . Your answer should not involve any integrals. Include units.

**Answer:** \_\_\_\_\_ **Units:** \_\_\_\_\_

- b. [5 points] Assume that the tank is entirely filled with cheese. Write an expression involving one or more integrals that gives the work done to pump all the cheese in the tank up to ground level. Your answer may include  $\delta(h)$ . Do not evaluate your integral(s). Include units.

**Answer:** \_\_\_\_\_ **Units:** \_\_\_\_\_

8. (continued)

- c. [5 points] Now assume that the tank is only filled up to a depth of 2 meters with cheese. The dispensary has a tap to the tank that is located 4 meters above ground level. The diagram below depicts the tank of cheese and the position of the tap. Write an expression involving one or more integrals that gives the work done to pump all the cheese in the tank up to the tap. Your answer may involve  $\delta(h)$ . Do not evaluate your integral(s). Include units.

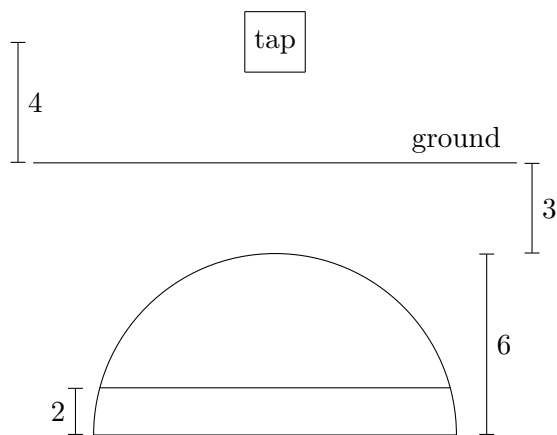

Answer: \_\_\_\_\_

Units: \_\_\_\_\_

9. [7 points] Let  $g(x)$  be a function that is twice-differentiable for all  $x$ . Additionally,  $g(x)$  has the following properties:

- $g(x)$  has no inflection points on the interval  $(0, 10)$
- $g'(x)$  does not change signs on the interval  $(0, 10)$
- $g'(5) = 1$
- $g''(7) = -2$

Define the function  $G(x)$  to be

$$G(x) = \int_1^x g(t) dt.$$

a. [2 points] Is  $G(x)$  concave up, concave down, or neither at  $x = 9$ ? No justification is required.

Circle one:    CONCAVE UP    CONCAVE DOWN    NEITHER

b. [5 points] With the blanks provided, order from least-to-greatest

$G(9)$ , LEFT(9), RIGHT(9), MID(9), TRAP(9)

where all the approximations above are of the definite integral  $G(9)$ . No justification is required.

\_\_\_\_\_  $\leq$  \_\_\_\_\_  $\leq$  \_\_\_\_\_  $\leq$  \_\_\_\_\_  $\leq$  \_\_\_\_\_