

Math 116 — Final Exam — December 12, 2024

**Write your 8-digit UMID number
very clearly in the box to the right,
and fill out the information on the lines below.**

Your Initials Only: _____ Your 8-digit UMID number (not unickname): _____

Instructor Name: _____ Section #: _____

1. Please neatly write your 8-digit UMID number, your initials, your instructor's first and/or last name, and your section number in the spaces provided.
2. This exam has 12 pages including this cover.
3. There are 10 problems. Note that the problems are not of equal difficulty, so you may want to skip over and return to a problem on which you are stuck.
4. Please read the instructions for each individual problem carefully. One of the skills being tested on this exam is your ability to interpret mathematical questions, so instructors will not answer questions about exam problems during the exam.
5. Show an appropriate amount of work (including appropriate explanation) for each problem, so that graders can see not only your answer but how you obtained it.
6. If you need more space to answer a question, please use the back of an exam page. Clearly indicate on your exam if you are using the back of a page, and also clearly label the problem number and part you are doing on the back of the page.
7. You are allowed notes written on two sides of a 3" × 5" note card. You are NOT allowed other resources, including, but not limited to, notes, calculators or other electronic devices.
8. For any graph or table that you use to find an answer, be sure to sketch the graph or write out the entries of the table. In either case, include an explanation of how you used the graph or table to find the answer.
9. Include units in your answer where that is appropriate.
10. Problems may ask for answers in *exact form*. Recall that $x = \sqrt{2}$ is a solution in exact form to the equation $x^2 = 2$, but $x = 1.41421356237$ is not.
11. You must use the methods learned in this course to solve all problems.

Problem	Points	Score
1	11	
2	10	
3	13	
4	14	
5	13	

Problem	Points	Score
6	5	
7	7	
8	12	
9	6	
10	9	
Total	100	

1. [11 points] Consider the polar curve $r = \theta \sin \theta$.

- a. [2 points] What are the x - and y -coordinates of the curve in terms of θ ? Use this to write a set of parametric equations for the curve.

Answer: $x(\theta) = \underline{\hspace{4cm}}$ and $y(\theta) = \underline{\hspace{4cm}}$

- b. [2 points] Which of the following points are on the curve $r = \theta \sin \theta$? Circle **all** options which apply.

i. $\theta = \frac{\pi}{2}, r = \frac{\pi}{2}$

v. $x = 0, y = \frac{\pi}{2}$

ii. $\theta = \frac{3\pi}{2}, r = \frac{3\pi}{2}$

vi. $x = 0, y = -\frac{\pi}{2}$

iii. $\theta = \pi, r = \pi$

vii. $x = 0, y = -\frac{3\pi}{2}$

iv. $\theta = 2\pi + \frac{\pi}{2}, r = \frac{\pi}{2}$

viii. NONE OF THESE

- c. [1 point] Find $\frac{dy}{d\theta}$ in terms of θ .

Answer: $\frac{dy}{d\theta} = \underline{\hspace{4cm}}$

- d. [2 points] At which of the following values of θ could the curve $r = \theta \sin \theta$ have a horizontal tangent line? Circle **all** options which apply.

i. $\theta = \frac{\pi}{2}$

iv. $\theta = \frac{2025}{2}\pi$

ii. $\theta = \pi$

v. NONE OF THESE

iii. $\theta = 2024\pi$

- e. [2 points] Which of the following could be the graph of the polar curve $r = \theta \sin \theta$, with $0 \leq \theta \leq 6\pi$? Circle the **one** best option.

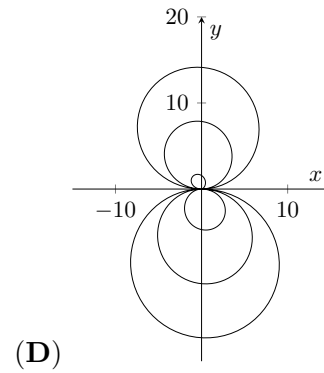
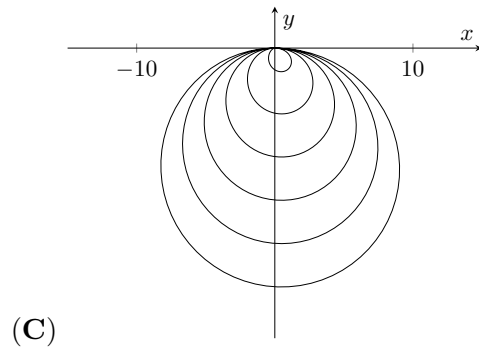
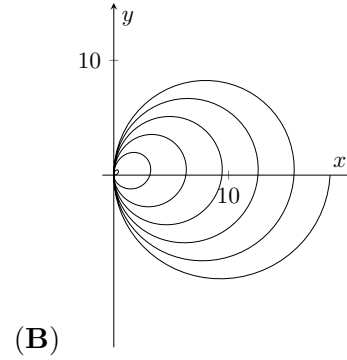
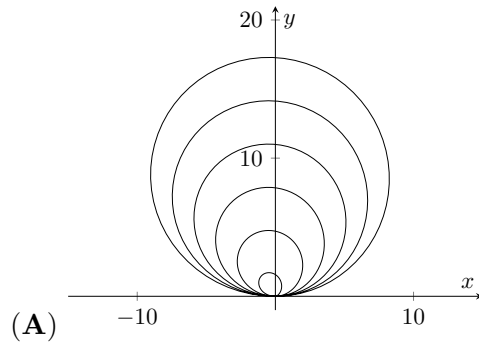

- f. [2 points] Which of the following integrals gives the length of the curve $r = \theta \sin \theta$, for $0 \leq \theta \leq 6\pi$? Circle **all** options which apply.

i. $\int_0^{6\pi} \sqrt{(\theta (\cos^2 \theta - \sin^2 \theta) + \sin \theta \cos \theta)^2 + (\sin \theta (2\theta \cos \theta + \sin \theta))^2} d\theta$

ii. $\int_0^{6\pi} \sqrt{(\theta \cos \theta + \sin \theta)^2 + (\theta \sin \theta)^2} d\theta$

iii. $\int_0^{2\pi} \sqrt{(\theta (\cos^2 \theta - \sin^2 \theta) + \sin \theta \cos \theta)^2 + (\sin \theta (2\theta \cos \theta + \sin \theta))^2} d\theta$

iv. $\int_0^{2\pi} \sqrt{(\theta \cos \theta + \sin \theta)^2 + (\theta \sin \theta)^2} d\theta$

v. NONE OF THE ABOVE.

2. [10 points] A power series centered at $x = 4$ is given by

$$\sum_{n=1}^{\infty} \frac{n+1}{11^n \cdot n^{3/2}} (x-4)^n.$$

The radius of convergence of this power series is 11 (do **not** show this). Find the **interval** of convergence of this power series. Show all your work, including full justification for series behavior.

Interval of convergence: _____

3. [13 points] In this week's snail race there are three snail competitors: snails A, B and C. All three snails start at the left wall of an aquarium (located at $x = 0$), and must cross the tank to the right-hand wall (located at $x = 100$). The paths of snails A and B are given below. All three snails start at $t = 0$, and stop when they reach the right-hand wall of the aquarium. The time t is measured in seconds, and all distances are in millimeters.

$$\begin{aligned} \text{A: } x(t) &= 10t, & y(t) &= \frac{t^2}{3} \\ \text{B: } x(t) &= t^2 - 7t + 82, & y(t) &= -\frac{t^3}{4} + 250 \end{aligned}$$

- a. [3 points] When do snails A and B finish the race? Which of these two snails reaches the finish line first?

Answer: Snail A finishes at $t =$ _____ seconds.

Answer: Snail B finishes at $t =$ _____ seconds.

Answer: The winner of these snails is snail _____.

- b. [4 points] Write an expression using one or more integrals for the distance that snail A travels during the race. Do not evaluate any integrals in your expression.

Answer: Snail A travels _____ mm.

- c. [3 points] Snail C travels in a straight line from the origin through the point $(40, 30)$. Which, if any, of the following could be a parametric equation describing snail C's *path* (disregarding speed) during the race? Circle **all** options which apply.

i. $x(t) = 40t, \quad y(t) = 30t$

iv. $x(t) = 30 \sin t, \quad y(t) = 40 \sin t$

ii. $x(t) = 30t, \quad y(t) = 40t$

v. $x(t) = 40 \sin(t + \frac{\pi}{2}), \quad y(t) = 30 \sin(t + \frac{\pi}{2})$

iii. $x(t) = \sin t, \quad y(t) = \frac{3}{4} \sin t$

vi. NONE OF THE ABOVE

- d. [3 points] Now assume that snail C travels at a constant speed of 10mm/s, still in a straight line from the origin through the point $(40, 30)$. Which, if any, of the following could be a parametric equation describing snail C's *motion* (including speed) during the race? Circle **all** options which apply.

i. $x(t) = 8t, \quad y(t) = 6t$

iv. $x(t) = 40 \sin t, \quad y(t) = 30 \sin t$

ii. $x(t) = 40t, \quad y(t) = 30t$

v. $x(t) = 10 \sin t, \quad y(t) = 10 \cos t$

iii. $x(t) = 8 \sin t, \quad y(t) = 6 \sin t$

vi. NONE OF THE ABOVE

4. [14 points]

Delema Inventions Inc is coming up with a design for a window. The window has the shape shown to the right, formed from the portion of the polar curve $r(\theta) = 1 + 2 \sin \theta$ with $y \geq 0$.

The outer loop (shaded) is made of green glass, and the inner loop (unshaded) is made of blue glass. The perimeter (including the perimeter of the inner loop, and the base along the x -axis) is lined with a black material.

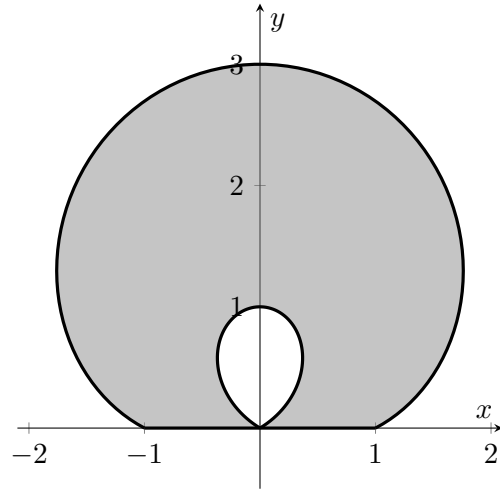

- a. [4 points] There are four values of θ with $0 \leq \theta < 2\pi$ such that $y = 0$ for the polar curve $r(\theta) = 1 + 2 \sin \theta$. Find all four values.

Answer: $\theta =$ _____

- b. [5 points] Find an expression involving one or more integrals for the length of black material Delema Inventions Inc will need to build the window. Remember that this material lines the edge of the outer loop, the edge of the inner loop, and also the base along the x -axis. Do not evaluate your integral(s).

Answer: _____

- c. [5 points] Find an expression involving one or more integrals for the area of green glass (the shaded region) which Delema Inventions Inc will need to build the window. Do not evaluate your integral(s).

Answer: _____

5. [13 points]

- a. [2 points] Find $\int \frac{x}{x+1} dx$, showing all of your work.

Answer: _____

Now consider the region in the first quadrant bounded by the x -axis, the lines $x = 2$ and $x = 11$, and the curve

$$f(x) = \frac{5x + 12}{x(x + 1)},$$

as shown in the figure to the right.

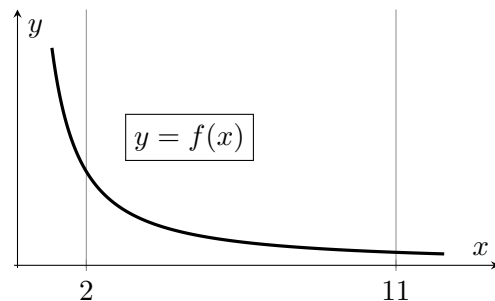

- b. [5 points] Find an expression involving one or more integrals for the volume of the solid of revolution given by rotating this region around the y -axis. Your expression should not contain the letter f . Do not evaluate your integral(s).

Answer: _____

- c. [4 points] Find a LEFT(3) approximation to your integral from part (b). Write out all the terms in your sum. You do not need to simplify, but your final answer should not involve the letter f .

Answer: _____

- d. [2 points] Evaluate your expression from part (b). You may use your answer from (a).

Answer: _____

6. [5 points] Consider the function $F(x)$ defined by its Taylor series around $x = 0$,

$$F(x) = \sum_{n=0}^{\infty} \frac{(-1)^n x^{2n+1}}{n!(2n+1)!}.$$

Find $F^{(2024)}(0)$ and $F^{(2025)}(0)$. You do not need to simplify your answers.

Answer: $F^{(2024)}(0) =$ _____ and $F^{(2025)}(0) =$ _____

7. [7 points] Consider the function

$$g(x) = \frac{3}{\sqrt{1+5x^2}}.$$

- a. [5 points] Give the first three nonzero terms of the Taylor series of $g(x)$ centered about $x = 0$. Show all your work.

Answer: _____

- b. [2 points] What is the radius of convergence of the Taylor series for $g(x)$?

Answer: _____

8. [12 points] For the following questions, determine if the statement is ALWAYS true, SOMETIMES true, or NEVER true, and circle the corresponding answer. Justification is not required.

a. [2 points] If a sequence a_n is monotone and bounded, then it converges.

Circle one: **ALWAYS** **SOMETIMES** **NEVER**

b. [2 points] If a sequence b_n is bounded, then it is monotone.

Circle one: **ALWAYS** **SOMETIMES** **NEVER**

c. [2 points] Let c_n be a sequence and $g(x)$ be a function with $g(n) = c_n$ for all $n \geq 1$. If $\int_1^\infty g(x) dx$ diverges, then $\sum_{n=1}^\infty c_n$ diverges.

Circle one: **ALWAYS** **SOMETIMES** **NEVER**

d. [2 points] The sequence d_n has $d_n \geq 0$ for $n \geq 1$. If $\lim_{n \rightarrow \infty} d_n = 0$, then $\sum_{n=1}^\infty (-1)^n d_n$ converges.

Circle one: **ALWAYS** **SOMETIMES** **NEVER**

e. [2 points] If $a > 0$, then the series $\sum_{n=1}^\infty \ln(n^a)$ converges.

Circle one: **ALWAYS** **SOMETIMES** **NEVER**

f. [2 points] The sequence k_n has $k_n > 0$ for all $n \geq 1$. If $\sum_{n=1}^\infty k_n$ converges, then $\sum_{n=1}^\infty \ln(k_n)$ converges.

Circle one: **ALWAYS** **SOMETIMES** **NEVER**

9. [6 points] Let $f(x)$ and $g(x)$ be two continuous and differentiable functions on $[1, \infty)$. Further, suppose these functions have the following properties:

- $F(x) = x(g(x) + 1)$ is an antiderivative of $f(x)$ for $x \geq 1$,
- $g(1) = 10$,
- $\lim_{x \rightarrow \infty} g(x) = -1$,
- $\lim_{x \rightarrow \infty} x^2 g'(x) = 17$.

Compute the value of the following improper integral if it converges. If it does not converge, use a **direct computation** of the integral to show its divergence. Be sure to show your full computation, and be sure to use **proper notation**.

$$\int_1^{\infty} f(x) \, dx$$

Circle one: **Diverges** **Converges to** _____

10. [9 points] The parts of this problem are unrelated. No justification is required for your answers.

a. [3 points] Which of the following could be the value of a if

$$1 - \frac{4a^2}{2!} + \frac{16a^4}{4!} - \frac{(2a)^6}{6!} + \frac{(2a)^8}{8!} - \dots = \frac{1}{2}?$$

Circle **all** options which apply.

i. $a = 0$

iv. $a = \frac{\pi}{2}$

vii. $a = \pi$

ii. $a = \frac{\pi}{6}$

v. $a = \frac{2\pi}{3}$

viii. NONE OF THESE

iii. $a = \frac{\pi}{3}$

vi. $a = \frac{5\pi}{6}$

b. [3 points] A graph of a function $y = f(x)$ is sketched below.

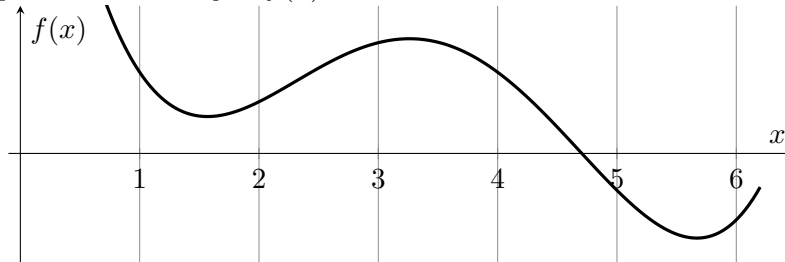

Suppose that for some constant b , the Taylor polynomial of degree 3 for $f(x)$ around $x = b$ is given by $P_3(x) = 4 - (x - b) + 2(x - b)^2 - 3(x - b)^3$. Which of the following could be the value of b ? Circle **all** options which apply.

i. $b = 1$

iii. $b = 3$

v. $b = 5$

ii. $b = 2$

iv. $b = 4$

vi. $b = 6$

c. [3 points] Which of the following is the Taylor series approximation around $x = 0$ to

$$\int_0^x e^{t^2} dt?$$

Circle the **one** best option.

i. 0

iv. $\sum_{n=0}^{\infty} \frac{x^n}{2(n!)}$

ii. $\sum_{n=0}^{\infty} \frac{x^{2n}}{n!}$

v. $\sum_{n=0}^{\infty} \frac{x^{2n+1}}{n!}$

iii. $\sum_{n=0}^{\infty} \frac{t^{2n}}{n!}$

vi. $\sum_{n=0}^{\infty} \frac{x^{2n+1}}{n!(2n+1)}$

“Known” Taylor series (all around $x = 0$):

$$\sin(x) = \sum_{n=0}^{\infty} \frac{(-1)^n x^{2n+1}}{(2n+1)!} = x - \frac{x^3}{3!} + \cdots + \frac{(-1)^n x^{2n+1}}{(2n+1)!} + \cdots \quad \text{for all values of } x$$

$$\cos(x) = \sum_{n=0}^{\infty} \frac{(-1)^n x^{2n}}{(2n)!} = 1 - \frac{x^2}{2!} + \cdots + \frac{(-1)^n x^{2n}}{(2n)!} + \cdots \quad \text{for all values of } x$$

$$e^x = \sum_{n=0}^{\infty} \frac{x^n}{n!} = 1 + x + \frac{x^2}{2!} + \cdots + \frac{x^n}{n!} + \cdots \quad \text{for all values of } x$$

$$\ln(1+x) = \sum_{n=1}^{\infty} \frac{(-1)^{n+1} x^n}{n} = x - \frac{x^2}{2} + \frac{x^3}{3} - \cdots + \frac{(-1)^{n+1} x^n}{n} + \cdots \quad \text{for } -1 < x \leq 1$$

$$(1+x)^p = 1 + px + \frac{p(p-1)}{2!} x^2 + \frac{p(p-1)(p-2)}{3!} x^3 + \cdots \quad \text{for } -1 < x < 1$$

$$\frac{1}{1-x} = \sum_{n=0}^{\infty} x^n = 1 + x + x^2 + x^3 + \cdots + x^n + \cdots \quad \text{for } -1 < x < 1$$

Select Values of Trigonometric Functions:

θ	$\sin \theta$	$\cos \theta$
$\frac{\pi}{6}$	$\frac{1}{2}$	$\frac{\sqrt{3}}{2}$
$\frac{\pi}{4}$	$\frac{1}{\sqrt{2}}$	$\frac{1}{\sqrt{2}}$
$\frac{\pi}{3}$	$\frac{\sqrt{3}}{2}$	$\frac{1}{2}$