

Math 116 — Second Midterm

March 2011

Name: _____ EXAM SOLUTIONS _____

Instructor: _____ Section: _____

1. **Do not open this exam until you are told to do so.**
2. This exam has 12 pages including this cover. There are 8 problems. Note that the problems are not of equal difficulty, so you may want to skip over and return to a problem on which you are stuck.
3. Do not separate the pages of this exam. If they do become separated, write your name on every page and point this out to your instructor when you hand in the exam.
4. Please read the instructions for each individual problem carefully. One of the skills being tested on this exam is your ability to interpret mathematical questions, so instructors will not answer questions about exam problems during the exam.
5. Show an appropriate amount of work (including appropriate explanation) for each problem, so that graders can see not only your answer but how you obtained it. Include units in your answer where that is appropriate.
6. You may use any calculator except a TI-92 (or other calculator with a full alphanumeric keypad). However, you must show work for any calculation which we have learned how to do in this course. You are also allowed two sides of a 3" × 5" note card.
7. If you use graphs or tables to find an answer, be sure to include an explanation and sketch of the graph, and to write out the entries of the table that you use.
8. **Turn off all cell phones and pagers**, and remove all headphones.

Problem	Points	Score
1	14	
2	14	
3	14	
4	12	
5	10	
6	14	
7	7	
8	15	
Total	100	

1. [14 points] Indicate if each of the following statements are true or false by circling the correct answer. **Justify your answers.**

- a. [2 points] The function $z(t) = \sin(at) + at$ is a solution to the differential equation $z'' + a^2z = a^3t$.

True

False

$$\text{Solution: } z' = a \cos(at) + a \quad z'' = -a^2 \sin(at)$$

$$z'' + a^2z = a^2 \sin(at) + a^2(\sin(at) + at) = a^3t.$$

- b. [3 points] The motion of a particle is given by the parametric curve $x = x(t)$, $y = y(t)$ for $0 \leq t \leq 3$ shown below. The arrows indicate the direction of the motion of the particle along the path. If the curve passes only twice through the origin, $x(1) = x(2) = 0$ and

$$y(1) = y(2) = 0 \text{ then } \frac{\frac{d}{dt}\left(\frac{dy}{dt}\right)}{\frac{dx}{dt}} > 0 \text{ for } t = 1.$$

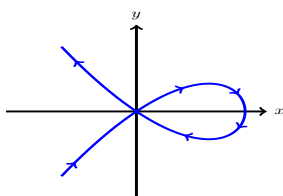

True

False

Solution: The first time that the curve passes through the origin at $t = 1$, the curve has negative concavity.

- c. [3 points] Euler's method yields an overestimate for the solutions to the differential equation $\frac{dy}{dx} = 4x^3 + 2x + 1$.

True

False

Solution: False, $y'' = 12x^2 + 2 > 0$ then Euler method is an underestimate since y is concave up.

- d. [3 points] The graph of $x = x(t)$ and $y = y(t)$ for $0 \leq t \leq 2$ is given below. If $y'(1) = 0$, then it must be the case that $(x(1), y(1)) = (0, 0)$.

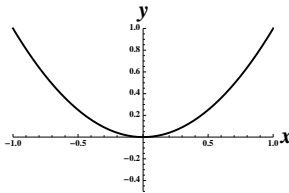

True

 False

Solution: False. The particle can stop at any point at time $t = 1$ in the parabola. Then $y'(1) = 0$ and $x'(1) = 0$ without necessarily be the case that $(x(1), y(1)) = (0, 0)$.

- e. [3 points] If $\int_0^2 f(x)dx$ is an improper integral, then $\int_0^1 f(x)dx$ must also be an improper integral.

True

 False

Solution: False. If $f(x) = \frac{1}{2-x}$ then $\int_0^2 f(x)dx$ is an improper integral, but $\int_0^1 f(x)dx$ is not an improper integral.

2. [14 points] A microphone at the point $r = 0$ detects sounds in a region enclosed by the cardioid $r = 2 + \frac{15}{8} \cos \theta$. The microphone is placed in front of the stage at an auditorium to record a musical band. Let d denote the smallest distance you must leave between the audience and the microphone to avoid recording any noise from the public in attendance.

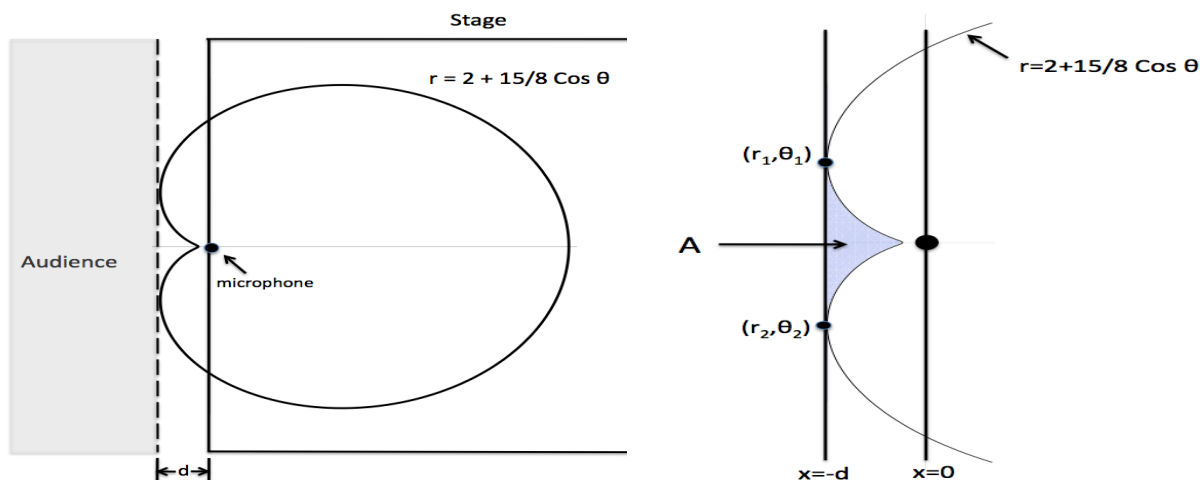

- a. [5 points] Write an integral that computes the area of the shaded region A in terms of θ_1 , θ_2 and d .

Solution: The line $x = -d$ in polar coordinates is $r = \frac{-d}{\cos \theta}$. Hence

$$A = \int_{\theta_1}^{\theta_2} \frac{1}{2} \left(\frac{-d}{\cos \theta} \right)^2 d\theta - \int_{\theta_1}^{\theta_2} \frac{1}{2} \left(2 + \frac{15}{8} \cos \theta \right)^2 d\theta$$

- b. [4 points] Write a formula in terms of θ that computes the value of the slope of the tangent line to the cardioid.

Solution:

$$\frac{dy}{dx} = \frac{y'}{x'} = \frac{\left(\left(2 + \frac{15}{8} \cos \theta \right) \sin \theta \right)'}{\left(\left(2 + \frac{15}{8} \cos \theta \right) \cos \theta \right)'} = \frac{\left(-\frac{15}{8} \sin \theta \right) \sin \theta + \left(2 + \frac{15}{8} \cos \theta \right) \cos \theta}{\left(-\frac{15}{8} \sin \theta \right) \cos \theta - \left(2 + \frac{15}{8} \cos \theta \right) \sin \theta}$$

- c. [3 points] Find an exact expression for the values of $0 \leq \theta < 2\pi$ at which the cardioid has a vertical tangent line. Full credit will not be given for decimal approximations.

Solution: $x' = \left(-\frac{15}{8} \sin \theta \right) \cos \theta - \left(2 + \frac{15}{8} \cos \theta \right) \sin \theta = -\sin \theta \left(2 + \frac{15}{4} \cos \theta \right) = 0$.

$\sin \theta = 0$ then $\theta = 0, \pi$.

$2 + \frac{15}{4} \cos \theta = 0$ then $\cos \theta = -\frac{8}{15}$.

This yields $\theta = 0, \pi, \theta_1 = \cos^{-1} \left(-\frac{8}{15} \right), \theta_2 = 2\pi - \cos^{-1} \left(-\frac{8}{15} \right)$

- d. [2 points] Find the value of d . Show all your work.

Solution: $d = -x(\theta_1) = -\left(2 + \frac{15}{8} \cos \theta_1 \right) \cos \theta_1 = \frac{8}{15}$

3. [14 points] A farmer notices that a population of grasshoppers is growing at undesirable levels in his crop. He decides to hire the services of a pest control company. They offer the farmer a pesticide capable of eliminating the grasshoppers at a rate of 1 thousand grasshoppers per week. In the absence of pesticides, it is estimated that the grasshopper population grows at a rate of 20 percent every week. Let $P(t)$ be the number of grasshoppers (in thousands) t weeks after the pesticide is applied to the crop. Then $P(t)$ satisfies

$$\frac{dP}{dt} = \frac{P}{5} - 1.$$

Suppose there are P_0 thousand grasshoppers in the crop at the time the pesticide is applied in the crop.

- a. [8 points] Find a formula for $P(t)$ in terms of t and P_0 .

Solution:

$$\begin{aligned}\frac{dP}{dt} &= \frac{P}{5} - 1. \\ \frac{dP}{dt} &= \frac{1}{5}(P - 5) \\ \frac{dP}{P - 5} &= \frac{1}{5}dt \\ \ln |P - 5| &= \frac{1}{5}t + C \\ P - 5 &= Be^{\frac{1}{5}t} \quad P(0) = P_0 = 5 + B \quad B = P_0 - 5. \\ P(t) &= 5 + (P_0 - 5)e^{\frac{1}{5}t}.\end{aligned}$$

- b. [3 points] Does the differential equation have any equilibrium solutions? List each equilibrium solution and determine whether it is stable or unstable. **Justify your answer.**

Solution: Equilibrium solutions: $P(t) = 5$. The equilibrium is unstable since for $P_0 > 5$ $P(t)$ increases and for $P_0 < 5$ $P(t)$ decreases.

- c. [3 points] Does the effectiveness of the pesticide depend on P_0 ? That is, is the pesticide guaranteed to eliminate the grasshopper population regardless of the value of P_0 , or are there some values of P_0 for which the grasshoppers will survive? If so, determine these values of P_0 .

Solution: The pesticide is effective if $P_0 < 5$ and ineffective if $P_0 \geq 5$.

4. [12 points] Another farmer notices the plague of grasshoppers has spread to his crop. He also visits the pest control company and requests a cheaper pesticide. This new pesticide is capable of eliminating the grasshoppers at a rate that decreases with time. Specifically, the rate at which grasshoppers are killed is given by the function $f(t) = \frac{3}{10}(4 - t)$ in thousands of grasshoppers per week at t weeks after the pesticide application. There is no pesticide remaining after 4 weeks. Suppose there are 3000 grasshoppers at the time the pesticide is applied.

Let $Q(t)$ the population of grasshoppers (in thousands) t weeks after this cheaper pesticide is applied to the crop. Then for $0 \leq t \leq 4$, $Q(t)$ satisfies

$$\frac{dQ}{dt} = \frac{Q}{5} - f(t).$$

- a. [1 point] Is this differential equation separable?

Solution: No

- b. [7 points] Using Euler's method, fill the table with the amount of grasshoppers (in thousands) in the crop during the first week. Show all your computations.

t	0	$\frac{1}{2}$	1
$Q(t)$	3	2.7	2.445

Solution:

$$Q(0) = 3 \text{ and } \Delta Q = \frac{1}{2}, \text{ then}$$

$$Q_0 = 3.$$

$$Q_1 = Q_0 + \left(\frac{Q_0}{5} - f(0)\right)\Delta Q = 2.7$$

$$Q_2 = Q_1 + \left(\frac{Q_1}{5} - f\left(\frac{1}{2}\right)\right)\Delta Q = 2.445$$

(problem 4 continued)

Use the slope field of the differential equation satisfied by $Q(t)$ to answer the following questions.

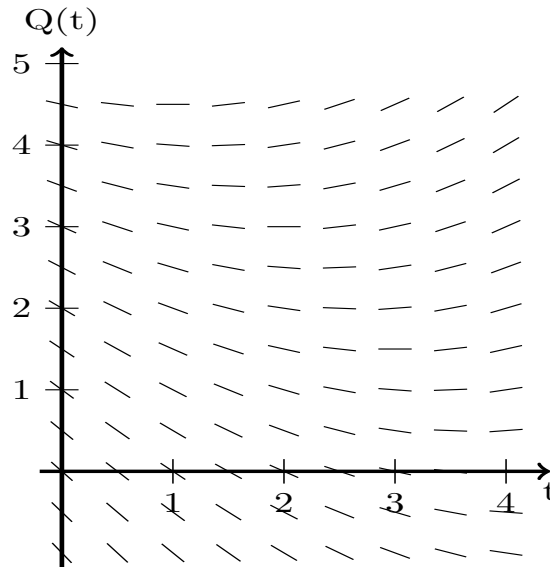

- c. [2 points] Does this equation have any equilibrium solutions in the region shown? List each equilibrium solution and determine whether it is stable or unstable. **Justify your answer.**

Solution: No equilibrium solutions. There is no y value at which all the lines have slope 0.

- d. [2 points] If the farmer's goal is to kill all the grasshoppers in his crop, will the pesticide be effective in this case? Draw the solution $Q(t)$ on the slope field.

Solution: No

5. [10 points]

When an ant finds food, it leaves a trail of chemicals from its nest to the food source. Other ants follow this chemical trail using their two antennae. When an ant possesses both antennae, it will walk in a straight line to the food. If you remove (amputate) the left antenna of an ant, it will walk in a pattern like the one shown in the second figure.

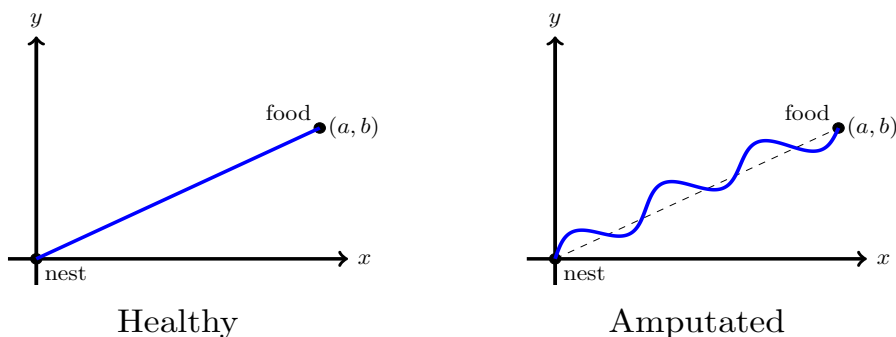

- a. [4 points] Write a parametric equation for the path of a healthy ant that starts at its nest at $(0, 0)$ when $t = 0$ and arrives at the food at (a, b) when $t = 1$.

Solution: $x(t) = at$ and $y(t) = bt$.

- b. [6 points] Suppose the parametric equation for the amputated ant is given by

$$x = x(t) \quad y = y(t).$$

Assume the ant starts walking at $t = 0$, arrives at the food at $t = 1$, and never pauses or backtracks. For each blank below, determine whether the number on the left is greater than, less than, or equal to the number on the right, and fill the blank with the symbol $>$, $<$, or $=$ respectively. **Justify your answers.**

Solution:

$$\frac{y'(1)}{x'(1)} > 0$$

Answer 1: The slope of the tangent line to the curve at (a, b) is positive

Answer 2: The quotient is undefined since the ant stopped.

$$x'(c) \text{ (for any } 0 < c < 1) > 0$$

The ant is always moving to the right

$$\int_0^1 \sqrt{(x'(t))^2 + (y'(t))^2} dt > \sqrt{a^2 + b^2}$$

The length of the line is shorter than the length of the curve

6. [14 points] A trash container is located outside a building. It starts to rain, causing water to enter the vessel. The trapezoidal side of the vessel is cracked and can only support 6000 newtons of force; eventually the water pressure causes the wall to break.

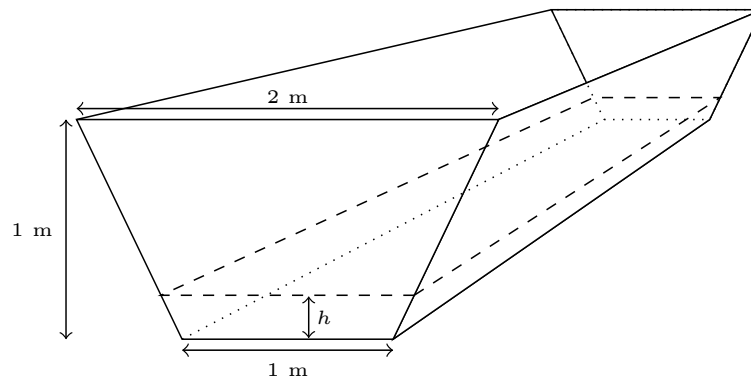

- a. [10 points] Write an integral expressing the amount of force on one trapezoidal side of the vessel when the height of the water is H meters. The density of rainwater is 1000 kg/m^3 , and the force of gravity is 9.8 N/kg .

Solution: Let h be the height of the slice.

$$\text{Force} = \delta_{\text{water}} g (\text{depth}) \text{Area}_{\text{slice}} = 1000(9.8)(H - h)(1 + h)\Delta h$$

$$\text{depth} = h$$

$$\text{Area}_{\text{slice}} = (1 + h)\Delta h$$

then

$$F = \int_0^H 1000(9.8)(H - h)(1 + h)dh$$

- b. [4 points] Determine the height in meters at which the trapezoidal wall will break. You may find your calculator very helpful for this problem.

$$\text{Solution: } \int_0^H 1000(9.8)(H - h)(1 + h)dh = 6000.$$

$$1000(9.8) \left(Hh - \frac{h^2}{2} + H\frac{h^2}{2} - \frac{h^3}{3} \Big|_0^H \right) = 6000$$

$$1000(9.8) \left(\frac{H^2}{2} + \frac{H^3}{6} \right) = 6000. \quad H = .962 \text{ meters.}$$

7. [7 points] A rod of length L meters has mass density δ_0 , where $0 \leq x \leq L$ represents the position in meters along the rod measured from its left endpoint. The force of gravitational attraction F between the rod and a particle of mass m lying in the same line as the rod at a distance a is given by

$$F = \int_0^L \frac{Gm\delta_0}{(a+x)^2} dx.$$

where G is the constant of gravitation.

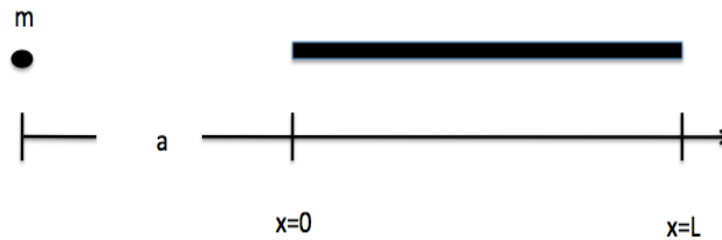

In certain cases (when the mass of the particle is small and the rod is long), you can assume that the rod has infinite length. Calculate the gravitational force between a rod of infinite length and a particle of mass m which is a meters away (arranged as shown above).

Solution:

$$\begin{aligned} \int_0^\infty \frac{Gm\delta_0}{(a+x)^2} dx &= Gm\delta_0 \lim_{b \rightarrow \infty} \int_0^b \frac{1}{(a+x)^2} dx \\ &= Gm\delta_0 \lim_{b \rightarrow \infty} \left. \frac{-1}{(a+x)} \right|_0^b \\ &= Gm\delta_0 \lim_{b \rightarrow \infty} \frac{-1}{(a+b)} + \frac{1}{a} \\ &= \frac{Gm\delta_0}{a} \end{aligned}$$

8. [15 points] Graphs of f, g and h are below. Each function is positive, is continuous on $(0, \infty)$, has a horizontal asymptote at $y = 0$ and has a vertical asymptote at $x = 0$. The area between $g(x)$ and $h(x)$ on the interval $(0, 1]$ is a finite number A , and the area between $g(x)$ and $h(x)$ on the interval $[5, \infty)$ is infinite. On the right is a graph of an antiderivative $G(x)$ of $g(x)$. It also has a vertical asymptote at $x = 0$.

Use the information in these graphs to determine whether the following three improper integrals **converge**, **diverge**, or whether there is **insufficient information to tell**. You may assume that f, g and h have no intersection points other than those shown in the graph. **Justify all your answers.**

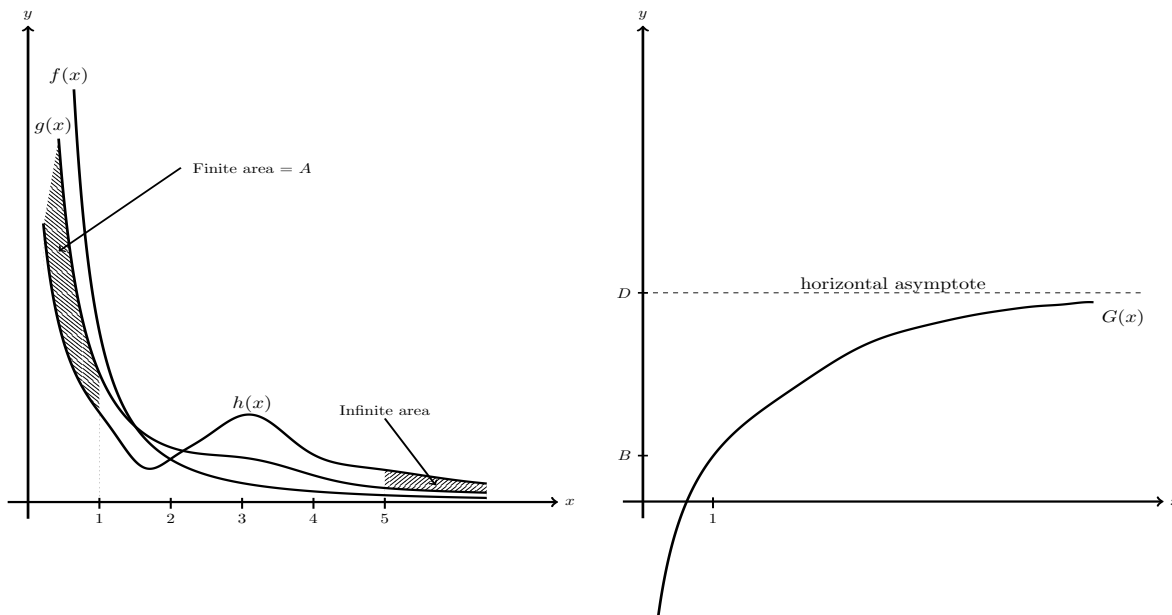

a. [3 points] $\int_1^{\infty} h(x) dx$

Solution: Diverges

$$\int_1^{\infty} h(x) dx = \int_1^5 h(x) dx + \int_5^{\infty} h(x) dx = \text{finite integral} + \text{divergent integral}$$

b. [4 points] $\int_0^1 g(x) dx$

Solution: Diverges

$$\int_0^1 g(x) dx = \lim_{b \rightarrow 0^+} \int_b^1 g(x) dx = \lim_{b \rightarrow 0^+} G(x) \Big|_b^1 = \lim_{b \rightarrow 0^+} G(1) - G(b) = \infty \text{ Diverges}$$

(problem 8 continued)

These graphs are the same as those found on the previous page.

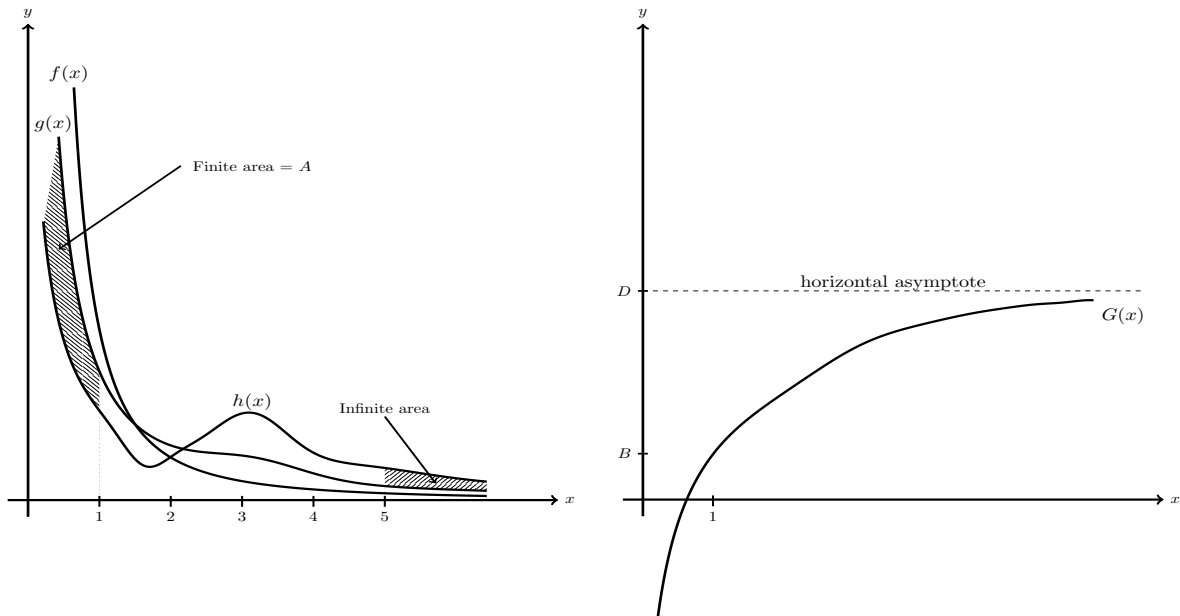

c. [3 points] $\int_0^1 h(x) dx$

Solution: Diverges since

$$\int_0^1 h(x) dx = \int_0^1 g(x) dx - \int_0^1 (g(x) - h(x)) dx = \text{divergent integral} + \text{finite integral}$$

d. [5 points] If $f(x) = 1/x^p$, what are all the possible values of p ? **Justify your answer.**

Solution:

$$\begin{aligned} \int_1^{\infty} g(x) dx &= \lim_{b \rightarrow \infty} \int_1^b g(x) dx \\ &= \lim_{b \rightarrow \infty} G(b) - G(1) = D - B \text{ converges} \end{aligned}$$

$$\int_3^{\infty} f(x) dx < \int_3^{\infty} g(x) dx \text{ convergent integral}$$

Hence $p > 1$.