

Math 116 — Second Midterm

March 23, 2015

Name: _____

Instructor: _____ Section: _____

1. **Do not open this exam until you are told to do so.**
 2. This exam has 11 pages including this cover. There are 11 problems. Note that the problems are not of equal difficulty, so you may want to skip over and return to a problem on which you are stuck.
 3. Do not separate the pages of this exam. If they do become separated, write your name on every page and point this out to your instructor when you hand in the exam.
 4. Please read the instructions for each individual problem carefully. One of the skills being tested on this exam is your ability to interpret mathematical questions, so instructors will not answer questions about exam problems during the exam.
 5. Show an appropriate amount of work (including appropriate explanation) for each problem, so that graders can see not only your answer but how you obtained it. Include units in your answer where that is appropriate.
 6. You may use any calculator except a TI-92 (or other calculator with a full alphanumeric keypad). However, you must show work for any calculation which we have learned how to do in this course. You are also allowed two sides of a $3'' \times 5''$ note card.
 7. If you use graphs or tables to find an answer, be sure to include an explanation and sketch of the graph, and to write out the entries of the table that you use.
 8. **Turn off all cell phones and pagers**, and remove all headphones.
 9. You must use the methods learned in this course to solve all problems.
-

Problem	Points	Score
1	16	
2	6	
3	4	
4	7	
5	8	
6	9	
7	9	
8	10	
9	10	
10	15	
11	6	
Total	100	

1. [16 points] Carla and Bobby run a race after spinning in circles for a good amount of time to make themselves dizzy. They start at the origin in the xy -plane and they race to the line $y = 5$. Assume the units of x and y are meters.

Bobby's position in the xy -plane t seconds after the race starts is

$$\left(-\sqrt{3}t \cos t, \frac{1}{\sqrt{3}}t \sin t\right)$$

and Carla's position in the xy -plane t seconds after the race starts is

$$(t \sin t, -t \cos t).$$

- a. [4 points] Write an integral that gives the distance that Carla travels during the first two seconds of the race. Do not evaluate your integral.

- b. [3 points] Find Carla's speed at $t = \pi$.

Carla's speed at $t = \pi$ is _____

- c. [4 points] Carla and Bobby are so dizzy that they run into each other at least once during the race. Find the first time $t > 0$ that they run into each other, and give the point (x, y) where the collision occurs.

They first run into each other at $t =$ _____

The collision occurs at $(x, y) =$ _____

- d. [5 points] Bobby's phone flies out of his pocket at $t = \pi/2$. It travels in a straight line in the same direction as he was moving at $t = \pi/2$. Find the equation of this line in Cartesian coordinates.

The equation for the line is _____

2. [6 points] Your friend the goliath frog is going to decorate the boundary of his lily pad with a string of tiny flowers. The boundary of the lily pad is given by a portion of the curve $r = 13 + 26 \cos(\theta)$ where r is measured in inches and θ is measured in radians. The part of the curve that traces out the lily pad is shown below in the xy -plane.

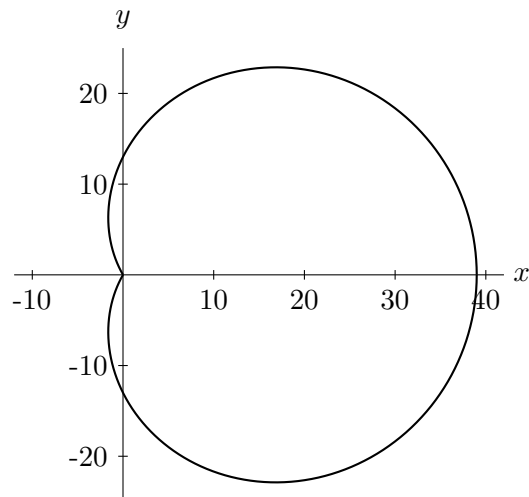

If the goliath frog is going to decorate only the part of the boundary of the lily pad for which $x \leq 0$, write an expression involving integrals for the length of the string of flowers required. Do not evaluate your integral.

3. [4 points] We can approximate the value of $\ln(1.5)$ by using the fact that $y = \ln(x)$ solves the differential equation

$$\frac{dy}{dx} = \frac{1}{x}$$

Approximate $\ln(1.5)$ by using Euler's method for the differential equation above with initial condition $y(1) = 0$ and with $\Delta x = 0.25$. Fill in the table with the y -values obtained at each step.

x	y
1.00	
1.25	
1.50	

Thus, $\ln(1.5) \approx$ _____

4. [7 points] You have an object attached to the end of a spring and you are trying to study its motion. Using Newton's second law and Hooke's law your physics teacher determines the displacement x from equilibrium of the object is a solution to the differential equation

$$\frac{d^2x}{dt^2} + 2x = 0.$$

For what values of A , B , and ω is

$$x(t) = A \cos(\omega t) + B \sin(\omega t)$$

a solution to the equation above satisfying the initial conditions $x(0) = 1$ and $x'(0) = 2$? Write your answers in the blanks provided and be sure to show all work.

$$A = \underline{\hspace{10em}}$$

$$B = \underline{\hspace{10em}}$$

$$\omega = \underline{\hspace{10em}}$$

5. [8 points] The graph of a slope field corresponding to a differential equation is shown below.

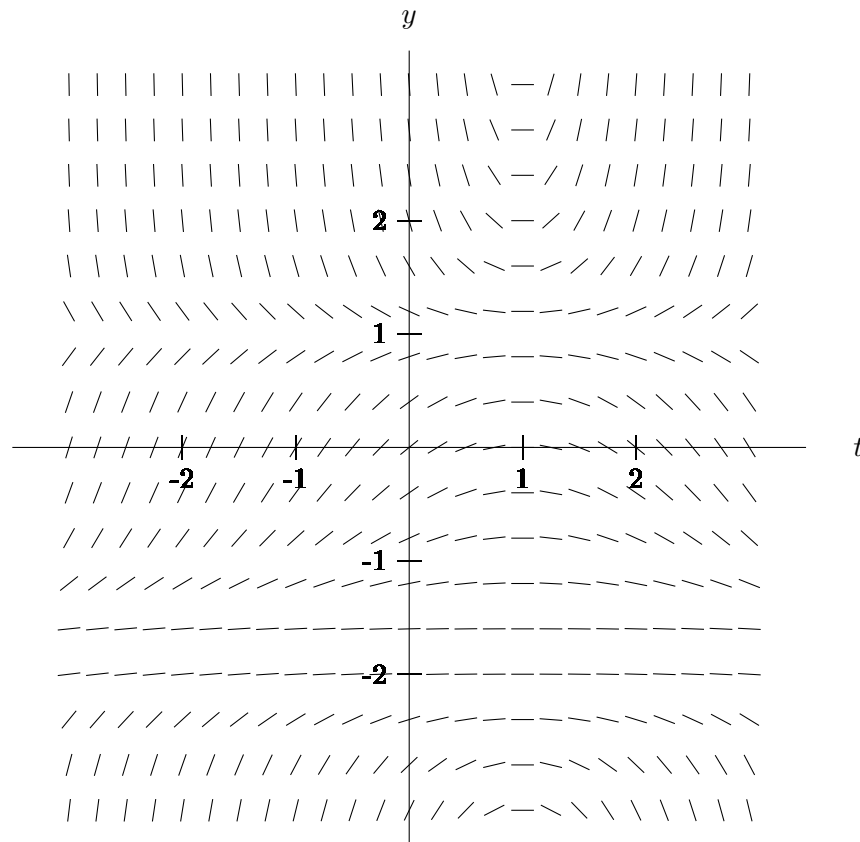

For all parts of this problem, no work is required and very little partial credit will be given.

- a. [2 points] On the slope field, sketch a solution curve passing through the point $(0, 0)$.
- b. [2 points] If you approximated the value of $y(1)$ using Euler's method starting at the point $(0, 0)$, would your approximated value be an overestimate or underestimate? Circle your answer.

OVERESTIMATE

UNDERESTIMATE

- c. [4 points] Which of the following differential equations could correspond to the slope field above? **Circle all that apply.**

$$\frac{dy}{dt} = (t - 1)(y - 1.1)(y + 1.8)^2$$

$$\frac{dy}{dt} = (t - 1)(y + 1.1)(y - 1.9)^2$$

$$\frac{dy}{dt} = (t - 1)(0.9 - y)(y + 1.8)^2$$

$$\frac{dy}{dt} = (t - 1)(y - 0.9)(y + 1.9)^4$$

$$\frac{dy}{dt} = (1 - t)(y - 1.1)(y + 1.9)^4$$

6. [9 points] An extremely sleepy graduate student is grading Math 116 exams. She has been drinking coffee all day, but it just is not enough. She hooks up a caffeine drip that delivers caffeine into her body at a constant rate of 170 mg/hr. The amount of caffeine in her body decays at a rate proportional to the current amount of caffeine in her body. The half-life of caffeine in her body is 6 hours.
- a. [4 points] Using the blank provided, write a differential equation which models the scenario described above. Use $Q(t)$ for the amount of caffeine in the graduate student's body, measured in mg, t for hours after she hooked up the caffeine drip, and $k > 0$ for the constant of proportionality.

$$\frac{dQ}{dt} = \underline{\hspace{10cm}}$$

- b. [5 points] Use the half-life of caffeine to determine the constant of proportionality.

7. [9 points] A certain cosmological model predicts the evaporation rate of a black hole to be inversely proportional to its mass squared. This gives a first order differential equation

$$\frac{dM}{dt} = \alpha \frac{1}{M^2}$$

where $M = M(t)$ is the mass of the black hole in kg, t is time in seconds, and α is the constant of proportionality.

- a. [5 points] Find the general solution using separation of variables.

- b. [4 points] How long will it take for a black hole with initial mass 8×10^{22} kg, which is approximately the mass of the moon, to evaporate if $\alpha = -\frac{8}{3} \times 10^{17}$ kg³/sec?

8. [10 points] Consider the differential equation

$$\frac{dy}{dt} = F(y)$$

where $F(y)$ is graphed below.

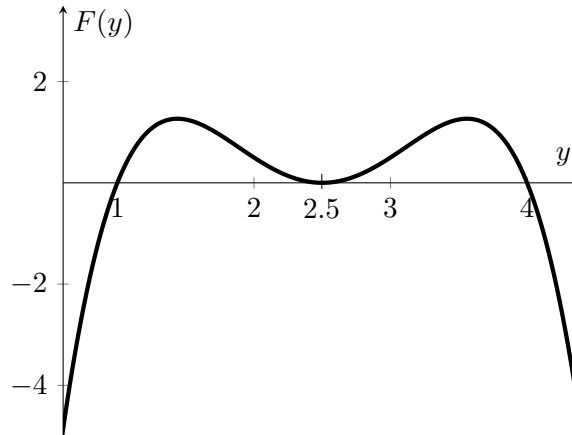

- a. [4 points] Identify all equilibrium solutions to the equation above.
- b. [4 points] Determine the stability of each equilibrium solution of the differential equation.
- c. [2 points] Suppose $y(t)$ solves the differential equation above subject to the initial condition $y(0) = 3$. Compute $\lim_{t \rightarrow \infty} y(t)$. Write your answer in the blank provided.

$$\lim_{t \rightarrow \infty} y(t) = \underline{\hspace{2cm}}$$

9. [10 points] Determine if the following integrals converge or diverge. If the integral converges, circle the word “converges” and give the **exact value** (i.e. no decimal approximations). If the integral diverges, circle “diverges”. In either case, **you must show all your work and indicate any theorems you use**. Any direct evaluation of integrals must be done **without using a calculator**.

a. [5 points] $\int_0^1 \ln(x) dx$

CONVERGES

DIVERGES

b. [5 points] $\int_2^{\infty} \frac{x + \sin x}{x^2 - x} dx$

CONVERGES

DIVERGES

10. [15 points] Consider the graph below depicting four functions for $x > 0$. The only point of intersection between any two of the functions is at $x = 1$. The functions $f(x)$ and $g(x)$ are both differentiable, and they each have $y = 0$ as a horizontal asymptote and $x = 0$ as a vertical asymptote.

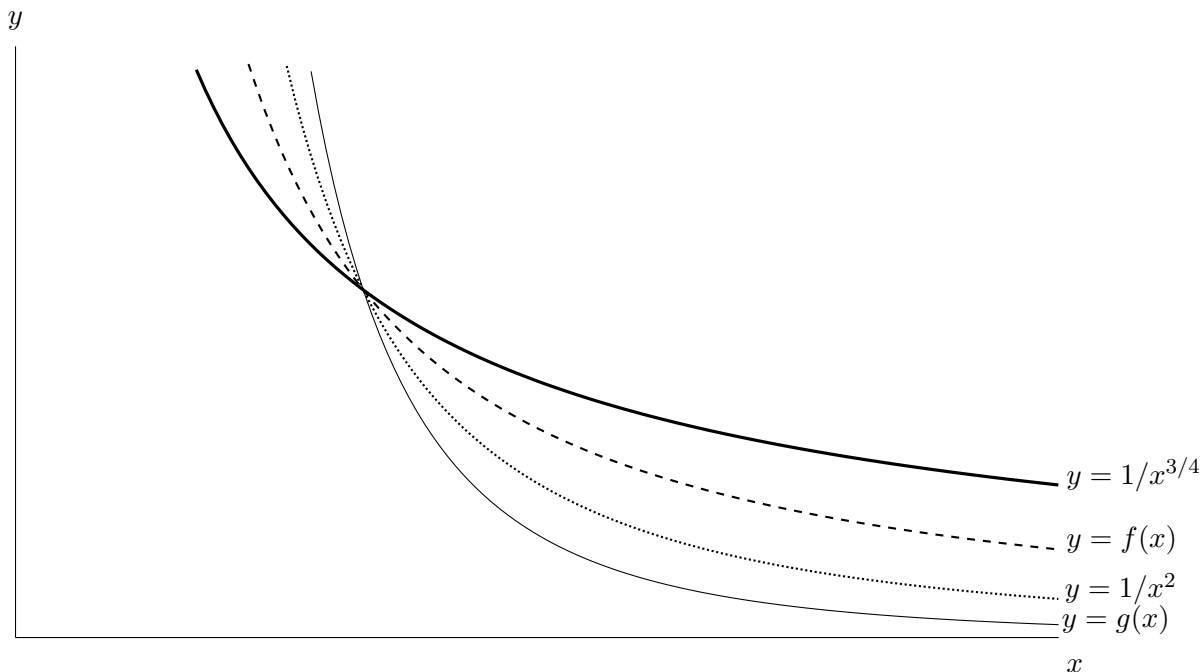

Use the graph to determine whether the following quantities converge or diverge, and circle the appropriate answer. If there is not enough information to determine convergence or divergence, circle “not enough information”. You do not need to show your work.

a. [3 points] $\int_1^{\infty} f(x) dx$

CONVERGES

DIVERGES

NOT ENOUGH INFORMATION

b. [3 points] $\int_0^1 g(x) dx$

CONVERGES

DIVERGES

NOT ENOUGH INFORMATION

c. [3 points] $\int_0^1 g'(x) e^{-g(x)} dx$

CONVERGES

DIVERGES

NOT ENOUGH INFORMATION

d. [3 points] $\int_1^{\infty} \sqrt{g(x)} dx$

CONVERGES

DIVERGES

NOT ENOUGH INFORMATION

- e. [3 points] The volume of the solid formed by rotating the region between $f(x)$ and the x -axis from $x = 1$ to $x = \infty$ about the x -axis

CONVERGES

DIVERGES

NOT ENOUGH INFORMATION

11. [6 points] Jane is trying to make a spaceship in the shape of the region enclosed by the polar curve

$$r = \frac{2 \cos(2\theta)}{\cos \theta}$$

where r is measured in meters and θ is measured in radians. The region is graphed below.

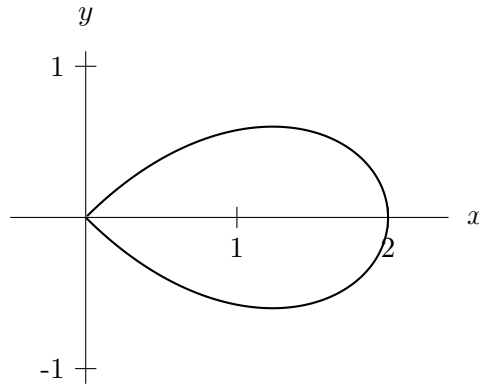

- a. [4 points] Find values of θ that trace out the boundary of the region exactly once.
- b. [2 points] Write an expression involving integrals that give the area of the region. Do not evaluate your integral.