

# Math 116 — First Midterm

February 8, 2016

UMID: \_\_\_\_\_ Initials: \_\_\_\_\_

Instructor: \_\_\_\_\_ Section: \_\_\_\_\_

---

1. **Do not open this exam until you are told to do so.**
  2. **Do not write your name anywhere on this exam.**
  3. This exam has 9 pages including this cover. There are 9 problems. Note that the problems are not of equal difficulty, so you may want to skip over and return to a problem on which you are stuck.
  4. Do not separate the pages of this exam. If they do become separated, write your UMID on every page and point this out to your instructor when you hand in the exam.
  5. Please read the instructions for each individual problem carefully. One of the skills being tested on this exam is your ability to interpret mathematical questions, so instructors will not answer questions about exam problems during the exam.
  6. Show an appropriate amount of work (including appropriate explanation) for each problem so that graders can see not only your answer, but also how you obtained it. Include units in your answer where that is appropriate.
  7. You may use a TI-84, TI-89, TI-Nspire or other approved calculator. However, you must show work for any calculation which we have learned how to do in this course. You are also allowed two sides of a  $3'' \times 5''$  note card.
  8. If you use graphs or tables to find an answer, be sure to include an explanation and sketch of the graph, and to write out the entries of the table that you use.
  9. **Turn off all cell phones, pagers, and smartwatches**, and remove all headphones.
- 

Problem	Points	Score
1	16	
2	12	
3	8	
4	5	
5	16	
6	10	
7	10	
8	12	
9	9	
Total	98	

1. [16 points] At a time  $t$  seconds after a catapult throws a rock, the rock has horizontal velocity  $v(t)$  m/s. Assume  $v(t)$  is monotonic between the values given in the table and does not change concavity.

$t$	0	1	2	3	4	5	6	7	8
$v(t)$	47	34	24	16	10	6	3	1	0

- a. [4 points] Estimate the average horizontal velocity of the rock between  $t = 2$  and  $t = 5$  using the trapezoid rule with 3 subdivisions. Write all the terms in your sum. Include **units**.
- b. [4 points] Estimate the total horizontal distance the rock traveled using a left Riemann sum with 8 subdivisions. Write all the terms in your sum. Include **units**.
- c. [4 points] Estimate the total horizontal distance the rock traveled using the midpoint rule with 4 subdivisions. Write all the terms in your sum. Include **units**.
- d. [4 points] A second rock thrown by the catapult traveled horizontally 125 meters. Determine whether the first rock or the second rock traveled farther, or if there is not enough information to decide. Circle your answer. Justify your answer.

the first rock

the second rock

not enough information

2. [12 points] The following is the graph of a function  $f(x)$ .

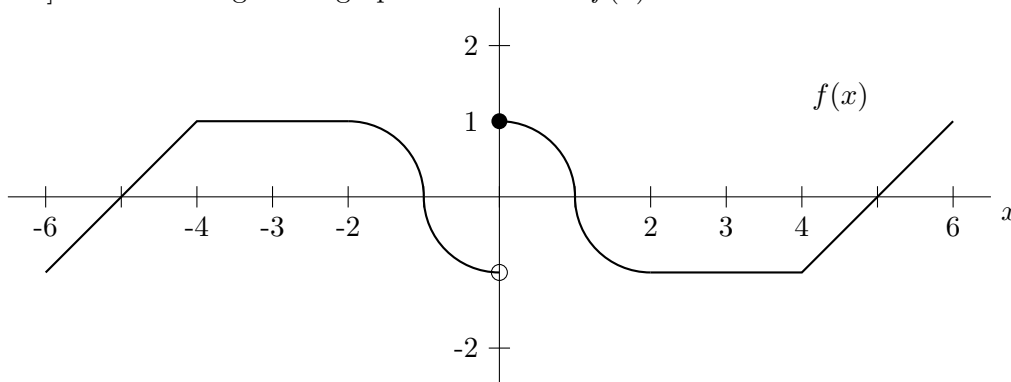

Note that the graph of  $f(x)$  is a quarter of a circle on each of the intervals  $[-2, -1]$ ,  $[-1, 0]$ ,  $[0, 1]$ ,  $[1, 2]$  and linear on each of the intervals  $[-6, -4]$ ,  $[-4, -2]$ ,  $[2, 4]$ ,  $[4, 6]$ .

Let  $F(x)$  be a function satisfying:

- $F(0) = 0$ .
- $F'(x) = f(x)$  for  $-6 < x < 0$  and  $0 < x < 6$ .

Carefully **sketch** a graph of  $F(x)$  using the axes provided below. If there are features of  $F(x)$  that are difficult for you to draw, indicate these on your graph. **Label** the  $x$ - and  $y$ -coordinates of the points on your graph of  $F$  at  $x = -3$ ,  $x = 1$  and  $x = 5$ .

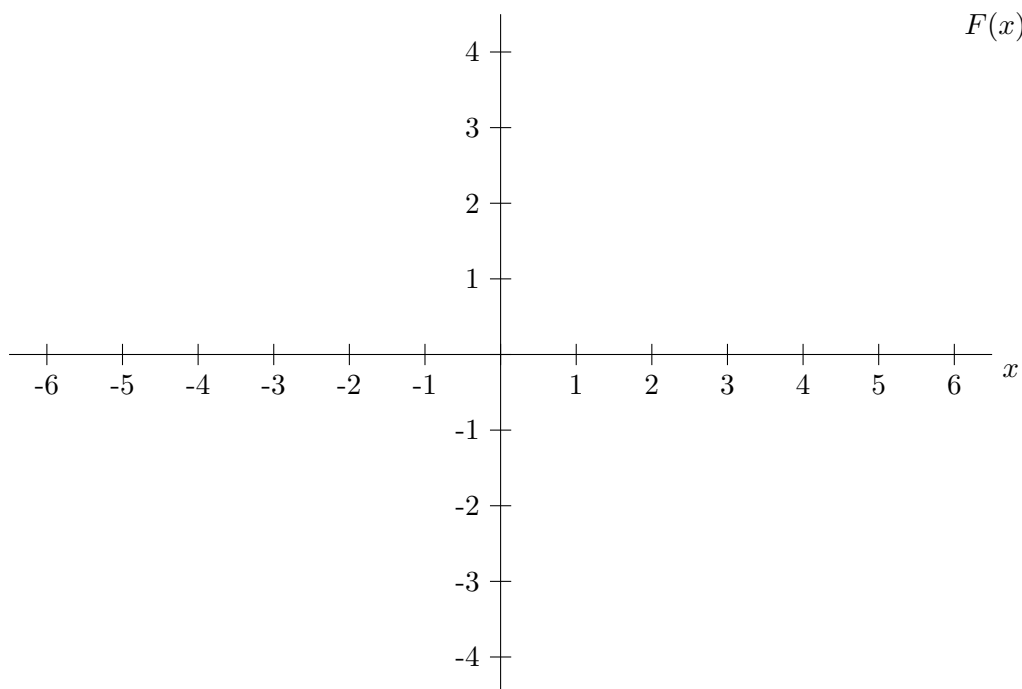

3. [8 points]

a. [4 points] Write a formula for the function  $G(t)$  whose derivative is  $\cos(5t)$  and whose graph passes through the point  $(0, 3)$ .

b. [4 points] Write a formula for the function  $H(t)$  whose derivative is  $\cos(t^5)$  and whose graph passes through the point  $(0, 3)$ .

4. [5 points] A deep sea diver is swimming to the surface of the water from a depth of 50 meters. At a depth of  $x$  meters below the surface of the water, the water pressure is changing at a rate of  $a(x)$  pascals/meter (pascal is the metric unit for pressure). If the water pressure is 592,000 pascals at a depth of 50 meters, write an expression involving integrals that gives the water pressure in pascals when the diver is  $x$  meters from the surface of the water.

5. [16 points] Suppose that  $f(x)$  is a function with the following properties:

- $\int_0^1 f(x) dx = -5$ .
- $\int_0^3 f'(x) dx = 10$ .
- The average value of  $f(x)$  on  $[1, 1.5]$  is  $-4$ .
- $\int_2^4 x f'(x) dx = 8$ .

In addition, a table of values for  $f(x)$  is given below.

$x$	0	1	2	3	4
$f(x)$	-7	-2	-2	$m$	0

Calculate (a)-(d) **exactly**. Show your work and do not write any decimal approximations.

a. [4 points]  $m =$

b. [4 points]  $\int_0^{1.5} f(x) dx =$

c. [4 points]  $\int_2^4 f(x) dx =$

d. [4 points]  $\int_4^{16} f'(\sqrt{x}) dx =$

6. [10 points] O-guk loves to eat vegetables, especially carrots. Every morning, he eats a bin filled to the top with shredded carrots. The bin is in the shape of a half cylinder and it is pictured below. The density of the carrots at height  $h$  m from the bottom of the bin is given by  $\delta(h)$  kg/m<sup>3</sup>.

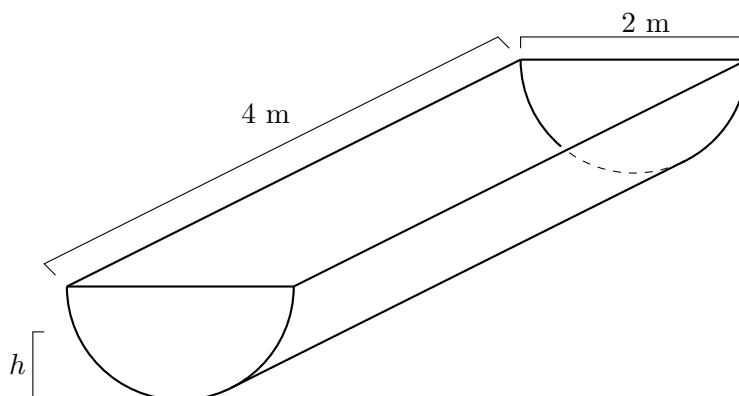

- a. [6 points] To get an idea of how much he eats, write an expression involving integrals that gives the mass of the carrots in the bin. Include **units**. Don't compute any integrals.
- b. [4 points] Write an expression involving integrals that gives the  $h$ -center of mass of the carrots in the bin. Don't compute any integrals.

7. [10 points] Maize and Blue Jewelry Company is trying to decide on a design for their signature aMaize-ing bracelet. There are two possible designs: type  $W$  and type  $J$ . The company has done research and the two bracelet designs are equally pleasing to customers. The design for both rings starts with the function  $C(x) = \cos\left(\frac{\pi}{2}x\right)$  where all units are in millimeters. Let  $R$  be the region enclosed by the graph of  $C(x)$  and the graph of  $-C(x)$  for  $-1 \leq x \leq 1$ .
- a. [5 points] The type  $W$  bracelet is in the shape of the solid formed by rotating  $R$  around the line  $x = 50$ . Write an integral that gives the volume of the type  $W$  bracelet. Include **units**.
- b. [5 points] The type  $J$  bracelet is in the shape of the solid formed by rotating  $R$  around the line  $y = -50$ . Write an integral that gives the volume of the type  $J$  bracelet. Include **units**.

8. [12 points] In the following questions, circle the correct answer. You do not need to show any work, but make sure your answer is clear. No points will be given for unclear answers.

a. [3 points] Let  $G(x)$  be an antiderivative of the function  $g(x) = e^{x^2}$  such that  $G(k) = 0$ . The arc length of the graph of  $G(x)$  from  $x = 0$  to  $x = 10$  is given by

$$\int_0^{10} \sqrt{1 + 4x^2 e^{2x^2}} dx \qquad \int_0^{10} \sqrt{1 + e^{2x^2}} dx \qquad \int_0^{10} \sqrt{1 + \left( \int_k^x e^{t^2} dt \right)^2} dx$$

b. [3 points] When he's very thirsty, O-guk drinks cans of orange juice at a rate of  $O(t)$  cans per minute, and he drinks cans of lemon juice at a rate of  $L(t)$  cans per minute. The total number of beverages that O-guk drinks,  $t$  minutes after he started, is given by

$$\int_0^x (O(t) + L(t)) dt \qquad \int_0^t (O(x) + L(x)) dx \qquad O(t) + L(t)$$

c. [3 points] If the function  $P(x)$  is positive, then the function  $M(x) = \int_0^{e^{-x}} P(t) dt$  is

increasing
constant
decreasing

d. [3 points] The volume of a solid whose base is a right triangle with two equal sides of length two, with square cross sections perpendicular to one of the sides of length two is

8
4/3
8/3
4



9. [9 points] The tank pictured below has height 2 meters, and the top and bottom are equilateral triangles with sides of length 1 meter. It is filled **halfway** with hot chocolate. The hot chocolate has uniform density  $1325 \text{ kg/m}^3$ . The acceleration due to gravity is  $9.8 \text{ m/s}^2$ . Calculate the work needed to pump all the chocolate to the top of the tank. Show all your work. Give an **exact** answer. Include **units**.

