

MATH 116 — PRACTICE FOR EXAM 1

Generated February 9, 2025

NAME: _____

INSTRUCTOR: _____ SECTION NUMBER: _____

1. This exam has 9 questions. Note that the problems are not of equal difficulty, so you may want to skip over and return to a problem on which you are stuck.
2. Do not separate the pages of the exam. If any pages do become separated, write your name on them and point them out to your instructor when you hand in the exam.
3. Please read the instructions for each individual exercise carefully. One of the skills being tested on this exam is your ability to interpret questions, so instructors will not answer questions about exam problems during the exam.
4. Show an appropriate amount of work (including appropriate explanation) for each exercise so that the graders can see not only the answer but also how you obtained it. Include units in your answers where appropriate.
5. You may use any calculator except a TI-92 (or other calculator with a full alphanumeric keypad). However, you must show work for any calculation which we have learned how to do in this course. You are also allowed two sides of a $3'' \times 5''$ note card.
6. If you use graphs or tables to obtain an answer, be certain to include an explanation and sketch of the graph, and to write out the entries of the table that you use.
7. You must use the methods learned in this course to solve all problems.

Semester	Exam	Problem	Name	Points	Score
Winter 2016	1	1	catapult	16	
Fall 2010	1	5	BTB	13	
Winter 2018	1	2	owl and dove	9	
Winter 2022	1	1		16	
Fall 2023	1	4	mushrooms	9	
Winter 2018	1	7	pyramid	10	
Fall 2016	1	3	fishtank	11	
Winter 2019	1	6	smoothies	12	
Winter 2022	1	4		11	
Total				107	

Recommended time (based on points): 97 minutes

1. [16 points] At a time t seconds after a catapult throws a rock, the rock has horizontal velocity $v(t)$ m/s. Assume $v(t)$ is monotonic between the values given in the table and does not change concavity.

t	0	1	2	3	4	5	6	7	8
$v(t)$	47	34	24	16	10	6	3	1	0

- a. [4 points] Estimate the average horizontal velocity of the rock between $t = 2$ and $t = 5$ using the trapezoid rule with 3 subdivisions. Write all the terms in your sum. Include **units**.
- b. [4 points] Estimate the total horizontal distance the rock traveled using a left Riemann sum with 8 subdivisions. Write all the terms in your sum. Include **units**.
- c. [4 points] Estimate the total horizontal distance the rock traveled using the midpoint rule with 4 subdivisions. Write all the terms in your sum. Include **units**.
- d. [4 points] A second rock thrown by the catapult traveled horizontally 125 meters. Determine whether the first rock or the second rock traveled farther, or if there is not enough information to decide. Circle your answer. Justify your answer.

the first rock

the second rock

not enough information

5. [13 points] In 2008, the burrito chain BTB began to operate a “Party Bus” powered by waste vegetable oil. If t is the number of days since 12:01 a.m. on October 11, 2010, then $f(t)$ is the amount in gallons per day of waste vegetable oil produced by BTB restaurant chain at time t and $g(t)$ is the amount consumed by the party bus in gallons per day at time t . Let $R(t)$ be the size of BTB’s vegetable oil reserves in gallons at time t . If BTB has 20 gallons held in reserve at time $t = 0$, use the graphs below to answer the following questions. All the questions below consider only $0 \leq t \leq 7$.

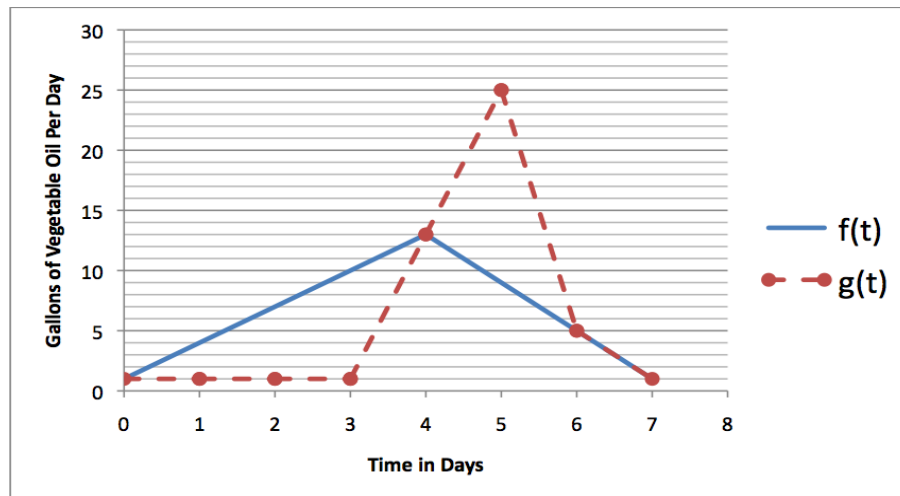

- a. [1 point] Estimate $R(3)$
- b. [2 points] When does BTB have a maximum volume of vegetable oil in reserve?
- c. [3 points] Suppose you need a ride to the airport on October 16. Will BTB have any vegetable oil in reserve to power their bus and drive you to the airport that day?
- d. [3 points] Find all critical points of $R(t)$.
- e. [4 points] On what intervals is $R(t)$ concave up? On what intervals is $R(t)$ concave down?

2. [9 points]

When Alejandra and Brontel were children they spent summer mornings chasing birds in flight. One memorable day they encountered an owl. The following graph shows the velocities $a(t)$ of Alejandra (solid) and $b(t)$ of Brontel (dashed), measured in meters per second, t seconds after the owl took off. The area of each region is given.

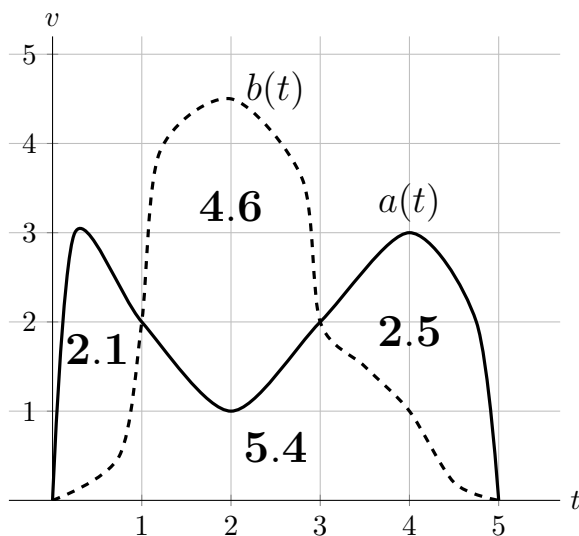

- a. [1 point] How far (in meters) do Alejandra and Brontel chase the owl?

Answer: _____

- b. [5 points] Suppose the owl ascends to a height of h meters according to $h(t) = \sqrt{t}$ where t is seconds since it went airborne. Let $L(h)$ be the number of meters Alejandra is ahead of Brontel when the owl is h meters above ground. Write an expression for $L(h)$ involving integrals and compute $L'(2)$.

Answer: $L(h) =$ _____

$L'(2) =$ _____

- c. [3 points] The next bird to pass is a dove. This time Alejandra runs twice as fast and Brontel runs three times as fast as they did when chasing the owl. How much faster (in m/s) is Brontel than Alejandra on average in the first 5 seconds?

Answer: _____

1. [16 points] Use the table to compute the following integrals. Write your answer using exact form on the blank provided. If there is not enough information available to answer the question, write N.I. You need to evaluate all integrals, but you do not need to simplify your final answer.

x	0	1	2	3	π	4	8	9
$f(x)$	0	2	5	9	-3	π	6	4
$f'(x)$	-7	-3	4	7	2	1	0	-5
$g(x)$	5	3	-1	2	6	2	-3	e

a. [4 points] $\int_0^4 x^{\frac{1}{2}} g'(\sqrt{x^3}) dx$

Answer: _____

b. [4 points] $\int_4^8 x f''(x) dx$

Answer: _____

c. [4 points] $\int_0^\pi \cos(t) f(\sin(t)) dt$

Answer: _____

d. [4 points] $\int_4^9 f''(\sqrt{x}) dx$

Answer: _____

4. [9 points] As Megan's assortment of mushrooms continues to grow, she starts tracking the growth of various mushrooms. She finds that one mushroom has an erratic growth rate. Its growth rate t days after it blooms is given by the function

$$m(t) = \frac{10 \cos(t)}{(\sin^2(t) + 1)(\sin(t) + 2)} + 6 \quad \text{for } 0 \leq t \leq 5,$$

measured in centimeters per day.

The height of Megan's mushroom 5 days after it blooms is given by the integral

$$\int_0^5 m(t) dt.$$

Evaluate this integral, showing all your work. Give an exact answer and include units. You may use the fact that

$$\frac{1}{(u^2 + 1)(u + 2)} = \frac{2 - u}{5(u^2 + 1)} + \frac{1}{5(u + 2)}.$$

Answer: _____

7. [10 points]

Ms. Parth made a pyramid for her niece and nephew. The pyramid is 10 inches tall and the base has the shape of a right triangle. When the pyramid is sitting on the table it looks like the figure to the right. The three angles at vertex V are right angles. (Dashed lines are not visible from this point of view. The figure may not be drawn to scale.)

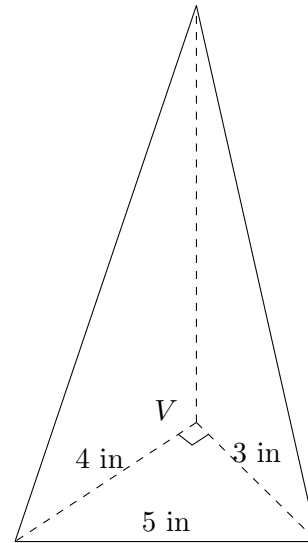

- a. [6 points] Write an integral that represents the total volume of the pyramid in cubic inches and evaluate it.

Answer: Integral: _____

Volume: _____

- b. [4 points] The children fail to share the pyramid, so Ms. Parth decides to cut it parallel to the table into two pieces of equal volume. How many inches H from the **top** of the pyramid should Ms. Parth cut? Round your answer to the nearest tenth of an inch.

Answer: $H =$ _____

3. [11 points] During a trip to the local aquarium, Steph becomes curious and decides to taste the fish food. The fish food tank is completely filled with food, and it is in the shape of a pyramid with a vertical hole through its center, illustrated below (the dashed lines are not part of the tank). The tank itself is 3 m tall, and the pyramid base is a square of side length 10 m. The top and bottom of the hole are squares of side length 4 m. The food is contained in the shaded region only, **not** in the hole.

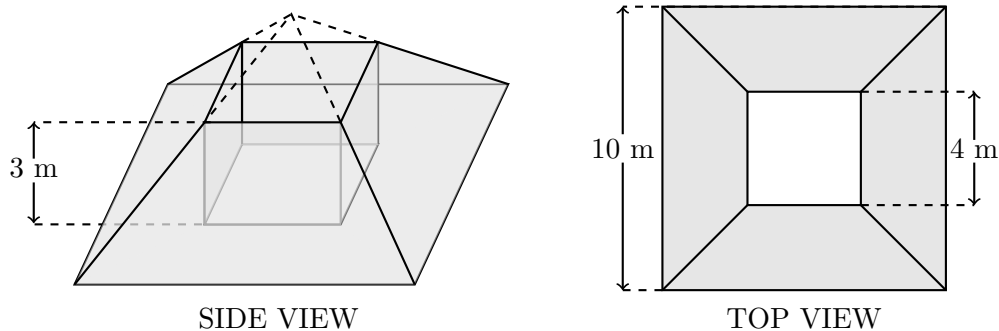

- a. [5 points] Write an expression that gives the approximate volume of a slice of fish food of thickness Δh meters, h meters from the bottom of the tank.
- b. [3 points] Suppose that the mass density of fish food is a constant δ kg/m³. Write, but do **not** evaluate, an expression involving integrals that gives the mass of fish food in the tank.
- c. [3 points] Write an expression involving integrals that gives \bar{h} , the h -coordinate of the center of mass of the fish food, where h is defined as above. Do **not** evaluate your expression.

6. [12 points] Ryan Rabbitt is making a smoothie with his new electric drink mixer. Mathematically, the container of the mixer has a shape that can be modeled as the surface obtained by rotating the region in the first quadrant bounded by the curves $y = 27$ and $y = x^{3/2}$ about the y -axis, where all lengths are measured in centimeters.
- a. [7 points] Write, but do not evaluate, two integrals representing the total volume, in cm^3 , the mixer can hold: one with respect to x , and one with respect to y .

Answer (with respect to x): _____

Answer (with respect to y): _____

- b. [5 points] Ryan adds 1600 cubic centimeters of liquid to his mixer. The container spins around the y -axis at a very high speed, causing the liquid to move away from the center of the container. The result is the solid made by rotating the shaded region around the y -axis in the diagram below. Note that this means that there is an empty space inside the liquid that has the shape of a cylinder.

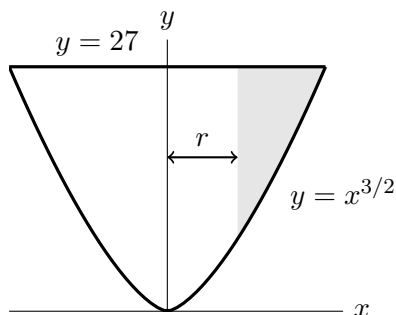

Let r be the radius of this cylinder of empty space. Set up an equation involving one or more integrals that you would use to solve to find the value of r . **Do not solve for r .**

Answer: _____

4. [11 points] Consider the shaded region bounded by $f(x) = 2 \cos^2\left(\frac{\pi x}{2}\right)$ and $g(x) = \sqrt{4 - (x - 2)^2} + 2$ shown below.

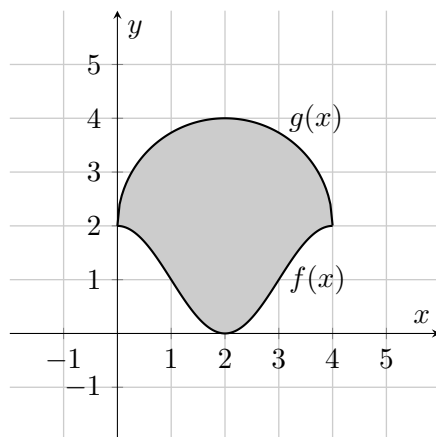

- a. [6 points] Write, but do not compute, an integral for the solid formed by rotating the region around the line $x = 5$.
- b. [5 points] Write, but do not compute, an expression involving one or more integrals for the perimeter of the region above. *Hint: The upper curve is a semicircle.*